

# Optimizing Chemotherapy Scheduling By Iteratively Solving a Recurrence Equation

Hui Jiang, Yifan Liu and Zheng Su

Volume 3, Number 2, Fall 2008

URI: [https://id.erudit.org/iderudit/aor3\\_2art06](https://id.erudit.org/iderudit/aor3_2art06)

[See table of contents](#)

Publisher(s)

Preeminent Academic Facets Inc.

ISSN

1718-3235 (digital)

[Explore this journal](#)

Cite this article

Jiang, H., Liu, Y. & Su, Z. (2008). Optimizing Chemotherapy Scheduling By Iteratively Solving a Recurrence Equation. *Algorithmic Operations Research*, 3(2), 175–185.

Article abstract

We illustrate how an iterative method and the idea of recurrence can be employed to optimize chemotherapy scheduling. We take the density of host and cancer cells as the states, and aim at minimizing the treatment period for each state. We derive the equation satisfied by the optimal values of the objective function at different states. The theorem of existence and uniqueness for the solution to this equation is proved, and some important properties of the optimal values of the objective function are presented. The optimal treatment schedule can be derived directly from the optimal objective function values at different states. We use an iterative method to solve the equation numerically. Some ideas to further enhance the model are discussed.



# Optimizing Chemotherapy Scheduling By Iteratively Solving a Recurrence Equation

Hui Jiang

Institute for Computational and Mathematical Engineering, Stanford University, USA.

Yifan Liu<sup>1</sup>

Department of Systems Engineering and Operations Research, George Mason University, USA

Zheng Su

Genentech Inc, USA

## Abstract

*We illustrate how an iterative method and the idea of recurrence can be employed to optimize chemotherapy scheduling. We take the density of host and cancer cells as the states, and aim at minimizing the treatment period for each state. We derive the equation satisfied by the optimal values of the objective function at different states. The theorem of existence and uniqueness for the solution to this equation is proved, and some important properties of the optimal values of the objective function are presented. The optimal treatment schedule can be derived directly from the optimal objective function values at different states. We use an iterative method to solve the equation numerically. Some ideas to further enhance the model are discussed.*

*Key words:* chemotherapy scheduling; recurrence equation; iterative method

## 1. Introduction

With the development of new drugs or treatment approaches, a fast growing number of different protocols for cancer treatment are coming into use. Although the limited human and financial resources for clinical trials prohibits the optimal protocols from being determined empirically, it is still necessary to suggest a priori improved drug schedules, according to certain criteria set by the physicians, such as life expectancy of a patient, side effects, quality of life, time and cost of treatment, etc. In this paper, we illustrate how an iterative algorithm can be applied in scheduling chemotherapy, which so far remains one of the most widely employed anticancer therapy modes.

In past years, there has been much work on operations research methods for ameliorating anticancer therapy. Wu & Zhu [1] is an example for radiotherapy, and Malinen et. al. [2] for surgery. Other operations research literature is devoted to chemotherapy, and dif-

ferent objectives are introduced. For example, among the extensive effort in the theoretical investigation of cancer chemotherapy control methods, Cox et. al. [3] and Swan [4] measure the treatment both by the overall toxicity it induces and by the overall number of cancer cells throughout the entire treatment period, while Murray [5] aims at minimizing the tumor size while limiting toxicity by keeping the host cell population above a given threshold.

While an analytical solution is found to the equations in [3], [4] and [5], it is unobtainable in the general case of Pereira et. al. [6], in which an optimization problem involving multiple drug chemotherapy is discussed. Instead, an iterative algorithm using Pontryagin's maximum principle is employed. Another example of numerical methods is Athanassios [7], which considered tumor and white blood cells' (WBC) responses to chemotherapy in an optimization problem. The problem searches a chemotherapy protocol which minimizes tumor load at the end of the first chemotherapy cycle and minimizes toxicity to the WBC. The model consists of ordinary delay differential equations, and the optimization is performed using nonlinear programming and nu-

---

Email: Yifan Liu<sup>1</sup> [yliu9@gmu.edu].

<sup>1</sup> corresponding author

merical methods.

Agur et. al. did a series of work, which took into account cell-cycle dynamics of tumor and host cells [8]-[13]. Their work suggested that intermittent delivery of cell-cycle phase-specific drugs, at intervals equivalent to the mean cell-cycle time, might minimize harmful toxicity without compromising therapeutic effects on target cells. Some explicit general formulas and algorithms were presented in their work. The underlying theories of the existence of this resonance phenomenon are discussed in Dibrov et. al. [14], Webb [15] and Johnson et. al. [16]. Some other examples of work related to cell-cycle phase-specific optimization problems include but are not restricted to Swan [17] and Swierniak [18,19].

In this paper, we use recurrence to describe the minimum treatment time. The main idea is as follows. We consider the density of host cells and tumor cells, which are written as  $(x, y)$ . Instead of searching for the best treatment schedule for each  $(x, y)$  separately, we regard each  $(x, y)$  as a state of a dynamic system, and define  $f(x, y)$  as the treatment time needed for a patient at state  $(x, y)$ , if an optimal schedule is employed. Therefore,  $f(x, y)$  is essentially the optimal value of our objective function, which corresponds to the optimal value of the decision variable, that is, the treatment schedule sequence, for  $(x, y)$ . Take  $\Delta t$  as the shortest time interval in reality during which chemotherapy is applied or not. If a patient is at state  $(x, y)$  at time  $t$ , then at  $t + \Delta t$ , the patient should move to state  $(x_1, y_1)$  if chemotherapy is applied during this  $\Delta t$ , or to state  $(x_2, y_2)$  if not. The relation among  $f(x_1, y_1)$ ,  $f(x_2, y_2)$  and  $f(x, y)$  is therefore established in an equation. Moreover, by setting  $f$  to zero when tumor density is below a certain level, which means cured, and setting  $f$  to infinity when tumor density is over a level or host density is below a level, which means terminal, we set up the boundary values for the equation. Solving this equation, we can obtain the minimum treatment time required for all states. Also, by studying the relation among the  $f$  values of the states, we can retrieve the optimal treatment schedule, i.e., to apply chemotherapy or not during a sequence of  $\Delta t$  time intervals.

We first prove the theorem of existence and uniqueness of the solution to the equation for  $f(x, y)$ , and study some of the properties of this equation, then solve it numerically. To emphasize our main point in the recurrence, we temporarily simplify other detailed aspects of the chemotherapy model, such as the dose amount of chemotherapy, the probabilistic model for moving from state to state, individualization of the parameters for dif-

ferent patients, and cell-cycle phase-specific scheduling. However, as discussed in section 6, all of these can be combined with our recurrence approach, so that the model can be further enhanced.

The rest of the paper is structured as follows. In section 2, we give detailed assumptions on the model and derive the recurrence equation. In section 3, we study the properties of the optimal objective function values, and prove the theorem of existence and uniqueness of the solution to the  $f(x, y)$  equation. In section 4, we introduce the iterative method to solve this equation numerically. In section 5, we present the numerical results for a set of parameters, and compare our method with the local search heuristic algorithm proposed by Agur et.al. [13]. Finally in section 6, we discuss how other detailed issues can be incorporated to modify our model in our future work.

## 2. Modeling the Minimum Treatment Time

In our model, we consider the density of two types of cells, the host cells and the tumor cells, denoted as  $x$  and  $y$ . By choosing a suitable unit, we can assume  $x = 1$  for a normal person without cancer. Also, we assume a person will die when the host cell density falls below a certain level  $x_d < 1$ . Similarly, we can choose a unit for tumor cells, so that  $y$  is at a comparable magnitude to  $x$ . Also, we assume the person is cured when  $y$  falls below a constant  $y_c$ , and terminal when  $y$  increases above a constant  $y_d$ . Chemotherapy is scheduled for  $x_d < x \leq 1$  and  $y_c < y < y_d$ .

While scheduling chemotherapy treatment, we need to decide whether to apply the treatment at any time. However, in reality, treatment should be applied continuously during at least a certain period, say, one hour or a couple of hours, and we cannot switch between treatment and no treatment too frequently. Therefore, we assume a constant  $\Delta t$ , which is the minimum time interval required in reality for continuous treatment. Suppose we start at time  $t = 0$ , then we need to decide to administer treatment or not for time intervals  $(t, t + \Delta t)$ ,  $(t + \Delta t, t + 2\Delta t)$ ,  $(t + 2\Delta t, t + 3\Delta t)$ , ... If we let 1 stand for treatment and 0 for no treatment, we are essentially searching for the optimal 0-1 sequence, such as 1100101100...

Suppose at  $t = 0$  the density of the cells are  $x$  and  $y$ , then at time  $\Delta t$  the density should depend on whether there was treatment during this  $\Delta t$ . Suppose the density of the cells are  $x^{(0)}$  and  $y^{(0)}$  in case of no treatment, and  $x^{(1)}$  and  $y^{(1)}$  in case of treatment. We define the

increment functions as

$$\Delta^{(l)}x = x^{(l)} - x, \Delta^{(l)}y = y^{(l)} - y, l = 0, 1.$$

Finding the accurate expression of the increment functions  $\Delta^{(0)}x$ ,  $\Delta^{(0)}y$ ,  $\Delta^{(1)}x$  and  $\Delta^{(1)}y$  lies in the field of biology and oncology, and is not the interest of our paper. Our goal is that, given the increment functions, we find the optimal chemotherapy schedule. As will be shown in the next section, our method will work for all increment functions that satisfy the following natural assumptions in chemotherapy.

- $\Delta^{(0)}x \geq 0$ ,  $\Delta^{(0)}y \geq 0$ , which means in case of no treatment, the density of cells cannot decrease due to cell growth.
- $\Delta^{(1)}x \leq 0$ ,  $\Delta^{(1)}y \leq 0$ , which means during chemotherapy treatment, the density of cells will not increase due to the effect of drug.
- If  $x_1 \leq x_2$ , then  $x_1 + \Delta^{(l)}x_1 \leq x_2 + \Delta^{(l)}x_2$ , i.e.,  $x_1^{(l)} \leq x_2^{(l)}$ , for  $l = 0, 1$ , and similarity for tumor cell density  $y$ . This means at the beginning of a period  $\Delta t$ , if state 1 has fewer cells than state 2, then given the same treatment choice during the time interval, state 1 will still have fewer cells than state 2 at the end of this interval.

Besides these assumptions, research also shows some other properties (listed below) regarding the monotonicity of the increment functions, which are not required to prove our theorems in the next section. However, while presenting the numerical results, we choose some increment functions that satisfy these properties.

- If there was no treatment, then the density of both host cells and tumor cells should increase, but the increasing speed varies. For tumor cells, it is well-known that they grow very fast, for example, geometrically or exponentially, i.e., the more tumor cells, the faster they grow. Therefore,  $\Delta^{(0)}y$  should increase with  $y$ .
- Host cell density, on the other hand, can never exceed its normal level, which is assumed to be 1 in the suitable unit, and research shows that when  $x$  is small, it grows somewhat like a tumor, but when  $x$  is approaching 1, it grows more and more slowly. Therefore,  $\Delta^{(0)}x$  should first increase as  $x$  increases, then reaches its maximum at some  $x_M$ , and then decrease to zero as  $x$  approaches 1. In any case,  $\Delta^{(0)}x$  should be smaller than  $1 - x$ .
- If treatment was applied during  $\Delta t$ , the density of both host cells and tumor cells should drop rapidly, since the drug strongly reduces the growth of cells. However, the drop of tumor is much faster since the drug involved in chemotherapy is supposed to be ori-

ented to the tumor, and hence has stronger effect on the tumor than on host cells. Also, the more cells there are, the more effect the chemotherapy has on them. Due to these facts, both  $\Delta^{(1)}x$  and  $\Delta^{(1)}y$  are negative, and both of their absolute values should increase with  $x$  and  $y$ .

We aim at minimizing the treatment time for each  $(x, y)$  by choosing the best schedule. We regard  $T$ , the time needed to cure a person with cell density  $(x, y)$ , as a function of  $x, y$  and  $s$ , where  $s$  is a sequence of boolean variables. Suppose all possible choices of  $s$  construct a set  $\mathcal{S}$ , then we are essentially solving

$$\min_{s \in \mathcal{S}} T(x, y, s),$$

for each pair  $(x, y)$  which satisfies  $x_d < x \leq 1$  and  $y_c < y < y_d$ .

However, the enormous size of  $\mathcal{S}$  prohibits direct solution, and the problem in some cases might be NP-complete [13]. Fortunately, we are more interested in the optimal value of  $T$  instead of the function  $T$  on the whole of  $\mathcal{S}$ .

If we define

$$f(x, y) = \min_{s \in \mathcal{S}} T(x, y, s),$$

i.e.,  $f(x, y)$  is the shortest possible time to cure a patient at state  $(x, y)$  if the optimal schedule is employed, then we can build up the relation of  $f$  for different states in the following way.

Suppose a patient is at  $(x, y)$ , then in the following time interval  $\Delta t$ , the density of cells may go to  $(x^{(0)}, y^{(0)})$  if no chemotherapy is applied, or to  $(x^{(1)}, y^{(1)})$  if there is chemotherapy treatment. Then from these two states, if optimal scheduling is employed thereafter, the shortest treatment time are  $f(x^{(0)}, y^{(0)})$  and  $f(x^{(1)}, y^{(1)})$  respectively. Since  $\Delta t$  has elapsed while moving from  $(x, y)$  to either of these two states, by optimality of the function  $f(x, y)$ , we have the relation

$$f(x, y) = \min(f(x^{(0)}, y^{(0)}), f(x^{(1)}, y^{(1)})) + \Delta t.$$

Moreover, for those already cured, the time needed is obviously zero, and for those terminal, we can assume the time needed is infinity, i.e., can never be cured. Therefore, we reach our equation for  $f(x, y)$  with boundary values as follows

$$f(x, y) = \begin{cases} \min(f(x^{(0)}, y^{(0)}), f(x^{(1)}, y^{(1)})) + \Delta t, \\ \quad x_d < x \leq 1 \text{ and } y_c < y < y_d \\ 0, \text{ for } x_d < x \leq 1 \text{ and } 0 \leq y \leq y_c \\ \infty, \text{ for } 0 \leq x \leq x_d \text{ or } y \geq y_d \end{cases} \quad (1)$$

For those who are neither terminal nor cured, the time needed should be either infinity (impossible to cure) or a multiple of  $\Delta t$ , which means we are seeking a solution to (1) which is  $k\Delta t$  everywhere in  $[x_d, 1] \times (y_c, y_d]$ , where  $k \in \mathbf{Z}^+$  or  $\infty$ . We define this kind of solution as a “regular solution”.

### 3. Properties of the Solution to the Recurrence Equation

Since we need to mathematically solve equation (1) to get  $f(x, y)$ , it is important to know, regardless of the biological meaning of it, whether there exists a solution to equation (1), and if so, whether the solution is unique. We have the following theorems, the proofs of which lead to the algorithms.

**Theorem 1** *There exists a regular solution to equation (1).*

**Proof.** The main idea of the proof comes from the value iteration algorithm, but here we are dealing with the case of continuous states. We iteratively define a sequence of functions  $f_i$  and prove they will converge to a function, which is the solution to equation (1). Define

$$f_0(x, y) = \begin{cases} 0, & x_d < x \leq 1 \text{ and } 0 \leq y \leq y_c \\ \infty, & 0 \leq x \leq x_d \text{ or } y > y_c \end{cases}$$

And for  $i = 1, 2, \dots$ , define

$$f_i(x, y) = \begin{cases} \min(f_{i-1}(x^{(0)}, y^{(0)}), f_{i-1}(x^{(1)}, y^{(1)})) + \\ \quad \Delta t, & x_d < x \leq 1 \text{ and } y_c < y < y_d \\ 0, & \text{for } x_d < x \leq 1 \text{ and } 0 \leq y \leq y_c \\ \infty, & \text{for } 0 \leq x \leq x_d \text{ or } y \geq y_d \end{cases} \quad (2)$$

We show that for every  $x$  and  $y$ ,  $f_i(x, y) \geq 0$ , and  $f_i(x, y) \geq f_{i+1}(x, y)$ .

In the area where  $0 \leq x \leq x_d$  or  $y \geq y_d$ ,  $f_i(x, y)$  is defined constantly as  $\infty$ , and in the area where  $x_d < x \leq 1$  and  $0 \leq y \leq y_c$ ,  $f_i(x, y)$  is defined constantly as 0. Hence both non-negativeness and monotonicity hold for these two cases trivially.

For the case where  $x_d < x \leq 1$  and  $y_c < y < y_d$ , we can show it by induction. For  $i = 0$ , it is trivial by

definition that  $f_0(x, y) \geq 0$  and  $f_0(x, y) \geq f_1(x, y)$ . If we have  $f_k(x, y) \geq 0$  and  $f_k(x, y) \geq f_{k+1}(x, y)$ , then for

$$\begin{aligned} f_{k+2}(x, y) &= \min(f_{k+1}(x^{(0)}, y^{(0)}), f_{k+1}(x^{(1)}, y^{(1)})) + \Delta t \\ &\leq \min(f_k(x^{(0)}, y^{(0)}), f_k(x^{(1)}, y^{(1)})) + \Delta t \\ &= f_{k+1}(x, y). \end{aligned}$$

Also,

$$\begin{aligned} f_{k+1}(x, y) &= \min(f_k(x^{(0)}, y^{(0)}), f_k(x^{(1)}, y^{(1)})) + \Delta t \\ &\geq \min(0, 0) + \Delta t \geq \Delta t > 0. \end{aligned}$$

Therefore, we proved that for each  $(x, y)$ ,  $f_i(x, y)$  is a monotonically decreasing sequence, while bounded below by 0, hence will converge as  $i$  goes to  $\infty$ . Define

$$f(x, y) = \lim_{i \rightarrow \infty} f_i(x, y),$$

then for  $x_d < x \leq 1$  and  $y_c < y < y_d$ , take the limit on both sides of equation (2), we can get

$$f(x, y) = \begin{cases} \min(f(x^{(0)}, y^{(0)}), f(x^{(1)}, y^{(1)})) + \Delta t, \\ \quad x_d < x \leq 1 \text{ and } y_c < y < y_d \\ 0, \text{ for } x_d < x \leq 1 \text{ and } 0 \leq y \leq y_c \\ \infty, \text{ for } 0 \leq x \leq x_d \text{ or } y \geq y_d \end{cases}$$

So the only thing left to prove for existence is that  $f(x, y)$  is either  $\infty$  or  $k\Delta t$ , for  $x_d < x \leq 1$  and  $y_c < y < y_d$ , but this can also be easily obtained via induction on  $f_i(x, y)$ . As  $f_0(x, y)$  can only be 0 or  $\infty$ ,  $f_1(x, y)$  can only be  $\Delta t$  or  $\infty$  in this region, etc. ■

**Theorem 2** *The regular solution to equation (1) is unique.*

**Proof.** Suppose there were two different regular solutions to equation (1), denoted by  $f(x, y)$  and  $g(x, y)$ . From boundary value 0 and  $\infty$ ,  $f$  and  $g$  can only be different when  $x_d < x \leq 1$  and  $y_c < y < y_d$ . Suppose at a certain  $(x, y)$  in this region,  $f(x, y) < g(x, y)$ , then  $f(x, y) < \infty$ , assume  $f(x, y) = k\Delta t$ , where  $k$  is a natural number.

Since both  $f$  and  $g$  are solutions, we have

$$f(x, y) = \min(f(x^{(0)}, y^{(0)}), f(x^{(1)}, y^{(1)})) + \Delta t,$$

and

$$g(x, y) = \min(g(x^{(0)}, y^{(0)}), g(x^{(1)}, y^{(1)})) + \Delta t.$$

Without loss of generality, assume  $f(x^{(0)}, y^{(0)}) \geq f(x^{(1)}, y^{(1)})$ , and denote  $(x^{(1)}, y^{(1)})$  with  $(x', y')$ , then

$$f(x, y) = f(x', y') + \Delta t,$$

which means

$$f(x', y') = (k - 1)\Delta t.$$

On the other hand,

$$\begin{aligned} g(x', y') &\geq \min(g(x^{(0)}, y^{(0)}), g(x', y')) \\ &= g(x, y) - \Delta t \\ &> f(x, y) - \Delta t \\ &= (k - 1)\Delta t. \end{aligned}$$

Therefore, starting from  $(x, y)$  where  $f(x, y) = k\Delta t$  and  $g(x, y) > k\Delta t$ , we move to another point  $(x', y')$  where  $f(x', y') = (k-1)\Delta t$  and  $g(x', y') > (k-1)\Delta t$ . Then do the same thing from point  $(x', y')$ , and repeat this for  $k$  times, we can finally reach a point  $(x^*, y^*)$  where  $f(x^*, y^*) = 0$  while  $g(x^*, y^*) > 0$ . However, since  $f$  is a regular solution, it can only be zero for  $x_d < x^* \leq 1$  and  $0 \leq y^* \leq y_c$ , so  $g(x^*, y^*) = 0$ , which results in a contradiction. Therefore, the regular solution to equation (1) must be unique. ■

Since equation (1) and the regularity condition satisfied by  $f(x, y)$  are derived from the optimality of  $T(x, y, s)$ , now that we have proved the existence and uniqueness of the regular solution to equation (1), we can from now on regard the regular solution  $f(x, y)$  and  $\min_{s \in \mathcal{S}} T(x, y, s)$  as the same thing.

A typical chemotherapy schedule involves both period of treatment and non-treatment. Tumor cells are killed during the treatment, while host cells are also killed to some extent. Therefore, we need a non-treatment period from time to time to let the host cells grow back to an acceptable level. However, if we choose the optimal schedule, we know intuitively that, given the same host cell density level, the more tumor cells, the longer it takes to cure the patient. On the other hand, given the same tumor cell density level, the fewer host cells, the longer it takes. These two points can be stated and proved in the following theorems.

**Theorem 3** Given  $\forall x \in (x_d, 1]$ , if  $y_1 \leq y_2$ , then  $f(x, y_1) \leq f(x, y_2)$ .

**Proof.** If  $f(x, y_2) = \infty$ , then  $f(x, y_1) \leq f(x, y_2)$  holds trivially. If  $f(x, y_2) < \infty$ , say,  $f(x, y_2) = k\Delta t$ , where  $k$  is a natural number, then according to the definition of  $f$ , there exists an optimal schedule  $s^* \in \mathcal{S}$ , such that

$$f(x, y_2) = T(x, y_2, s^*) = \min_{s \in \mathcal{S}} T(x, y_2, s) = k\Delta t.$$

and during these  $k$  periods, host cell level never drops below  $x_d$ , while at the end of the  $k$ th period, tumor level goes to  $y'_2$  which is below  $y_c$ , so that it can be considered cured.

Now starting from state  $(x, y_1)$ , and following the same schedule  $s^*$ , from the assumption that  $y_1 + \Delta^{(l)}y_1 \leq y_2 + \Delta^{(l)}y_2$  if  $y_1 \leq y_2$ , after each time period, the host cell level will be the same as if we start from state  $(x, y_2)$ , while the tumor level should reach a level lower than that from state  $(x, y_2)$ , since  $y_1 \leq y_2$ . Therefore, during these  $k$  periods, host cell level will never drop below  $x_d$ , either, while at the end of the  $k$ th period, tumor level drops to  $y'_1$ , which satisfies  $y'_1 \leq y'_2 \leq y_c$ .

Therefore, state  $(x, y_1)$  can also be cured after  $k\Delta t$  following schedule  $s^*$ , and we can conclude the optimal treatment time for  $(x, y_1)$  is at most  $k\Delta t$ , i.e.,  $f(x, y_1) \leq f(x, y_2)$ . ■

Similarly, we can prove a parallel result,

**Theorem 4** Given  $\forall y \in (y_c, y_d)$ , if  $x_1 \leq x_2$ , then  $f(x_1, y) \geq f(x_2, y)$ .

**Proof.** Omitted. ■

#### 4. Algorithms

The proposed approach for scheduling chemotherapy consists of two steps. The first step is to numerically solve equation (1) to get the optimal treatment time  $f(x, y)$ , and the second step is to determine the 0-1 sequence from  $f(x, y)$  of the whole domain.

In the proof of the existence of a solution, we constructed a solution by forming a sequence of  $f_i(x, y)$  and taking the limit of it. The numerical algorithm is based on the same idea. However,  $f_i(x, y)$  is defined on the whole domain of  $x$  and  $y$  having uncountable points, which makes it impossible to implement directly. What we need to do is mesh the domain into a finite number of grid points, and update the value of  $f$  on the grid. If  $(x, y)$  moves to a non-grid point after  $\Delta t$ , we use linear interpolation from the value of its 4 nearby grid points as the value of  $f(x + \Delta^{(l)}x, y + \Delta^{(l)}y)$ . The interpolation may violate the regularity condition which requires the solution to be a multiple of  $\Delta t$ . However, we may round the converged solution off to the closest integer after the algorithm terminates.

We set the whole domain of interest  $\mathcal{D}$  as  $x \in [x_{min}, 1]$  and  $y \in [y_{min}, y_{max}]$ . Here  $x_{min}$  is chosen somewhat smaller than  $x_d$ ,  $y_{min}$  smaller than  $y_c$  and  $y_{max}$  larger than  $y_d$ , such that we can ensure any state  $(x, y)$  within the region  $[x_d, 1] \times [y_c, y_d]$  will not move out of  $[x_{min}, 1] \times [y_{min}, y_{max}]$  after a time interval  $\Delta t$ .

We mesh  $\mathcal{D}$  with step size  $\delta x$  and  $\delta y$ . Let  $M = (1 - x_{min})/\delta x$ ,  $N = (y_{max} - y_{min})/\delta y$ , then the whole domain is meshed to  $(x_i, y_j)$  as grid points, for  $i =$

$0, 1, \dots, M, j = 0, 1, \dots, N$ . By adjusting  $x_{min}$ ,  $y_{min}$  and  $y_{max}$ , we can assume  $x_d$ ,  $y_c$  and  $y_d$  are on the grid points, i.e.  $x_d = x_{min} + k_{x_d}\delta x$ ,  $y_c = y_{min} + k_{y_c}\delta y$  and  $y_d = y_{min} + k_{y_d}\delta y$ , where  $k_{x_d}$ ,  $k_{y_c}$  and  $k_{y_d}$  are natural numbers. Then we can construct a sequence of  $f$  values on the grid points according to the proof of existence of the solution; the main idea is illustrated in Figure 1 and the detailed implementation is summarized in Algorithm 1.

After  $f(x_i, y_j)$  are determined, we can find out the optimal chemotherapy schedule for any  $(x, y)$ , by iteratively comparing  $f(x^{(0)}, y^{(0)})$  and  $f(x^{(1)}, y^{(1)})$ , and store the 0-1 schedule in an array denoted by  $S$ . This is illustrated in Algorithm 2.

If  $f(x, y) = \infty$ , and we report that the patient cannot be cured, it does not mean that we should give up treatment. Instead, we shall aim at maximizing the survival time before death. This can be achieved by defining another function of the survival time as  $T'(x, y, s)$ , and the optimal survival time as

$$g(x, y) = \max_{s \in \mathcal{S}} T'(x, y, s).$$

Then similar to  $f(x, y)$ , we can have the dynamic equation for  $g(x, y)$  as

$$g(x, y) = \max(g(x^{(0)}, y^{(0)}), g(x^{(1)}, y^{(1)})) + \Delta t,$$

for  $x_d < x \leq 1$  and  $y_c < y < y_d$ , and set  $g(x, y) = 0$  for those dead and  $g(x, y) = \infty$  for those cured. Then, following the same steps in previous sections, we can also construct the theorems and algorithms for the optimal survival time, for which we omit the details here.

## 5. Numerical Results and Comparative Studies

In this section, we first demonstrate the performance of the proposed approach for a set of increment functions given as follows.

In case of no treatment, the tumor cells grow exponentially as

$$y^{(0)} = yr_c^{\frac{\Delta t}{t_c}},$$

where  $r_c$  is a constant, and  $t_c$  is the length of the life cycle of tumor cells.

The host cells also grow exponentially with  $t_h$  as the length of the life cycle. However, the base  $t_h$  is no longer a constant as  $t_c$ . Since the host cells density cannot grow beyond 1, following the assumptions in section 2, we can construct  $t_h = \min(2, \frac{x+1}{2x})$ , which means the

number of host cells can at most double after each life cycle, and

$$x^{(0)} = x(\min(2, \frac{x+1}{2x}))^{\frac{\Delta t}{t_h}}.$$

In case of chemotherapy, we simply assume a fraction  $\alpha_h$  and  $\alpha_c$  of  $t_h$  and  $t_c$  will be deducted, so that the total density will decrease,

$$x^{(1)} = x(\min(2, \frac{x+1}{2x})(1 - \alpha_h))^{\frac{\Delta t}{t_h}},$$

$$y^{(1)} = y(r_c(1 - \alpha_c))^{\frac{\Delta t}{t_c}}.$$

We carry out our experiment for two example sets of parameters listed in Table 1. For simplicity, we take the time unit as  $\Delta t = 1$ .

If we choose our grid size as  $\delta_x = 0.001$  and  $\delta_y = 0.001$ , using Algorithm 1, we can get the optimal treatment time for the whole domain of our interest. Neglecting those states that are incurable, we have the results shown in Figure 1.

Following Algorithm 2, we give our optimal treatment time (OTT) and optimal chemotherapy scheduling 0-1 sequence for various  $(x, y)$  states listed in Table 2.

We can see from the results that more frequent chemotherapy treatment is required in example 2 than in example 1. This is because the drug is less effective on tumor while having more impact on host cells, i.e., smaller  $\alpha_c$  and larger  $\alpha_h$ .

To illustrate the advantages of the proposed approach, we compare it with the local search heuristic algorithm proposed by Agur et.al. [13], the most recent work on optimizing chemotherapy scheduling. Their multiple-start local search algorithm searches for a locally optimal treatment schedule that maximizes a well-defined fitness function. The fitness function is mainly composed of three parts, which depend on the cell density, the index of whether the patient is cured, and the time of cure. The algorithm divides the life-cycle of a cell into critical and non-critical phases. By setting the critical phase to be the whole life-cycle, this algorithm and our proposed approach are comparable for the same set of parameters as in Examples 1 and 2, and the comparative results on optimal treatment time are summarized in Table 3.

From Table 3, we can see that for half of the 12 cases considered, both approaches achieved the same optimal treatment time. For the other 6 cases, especially for cases in which it takes a relatively longer time to

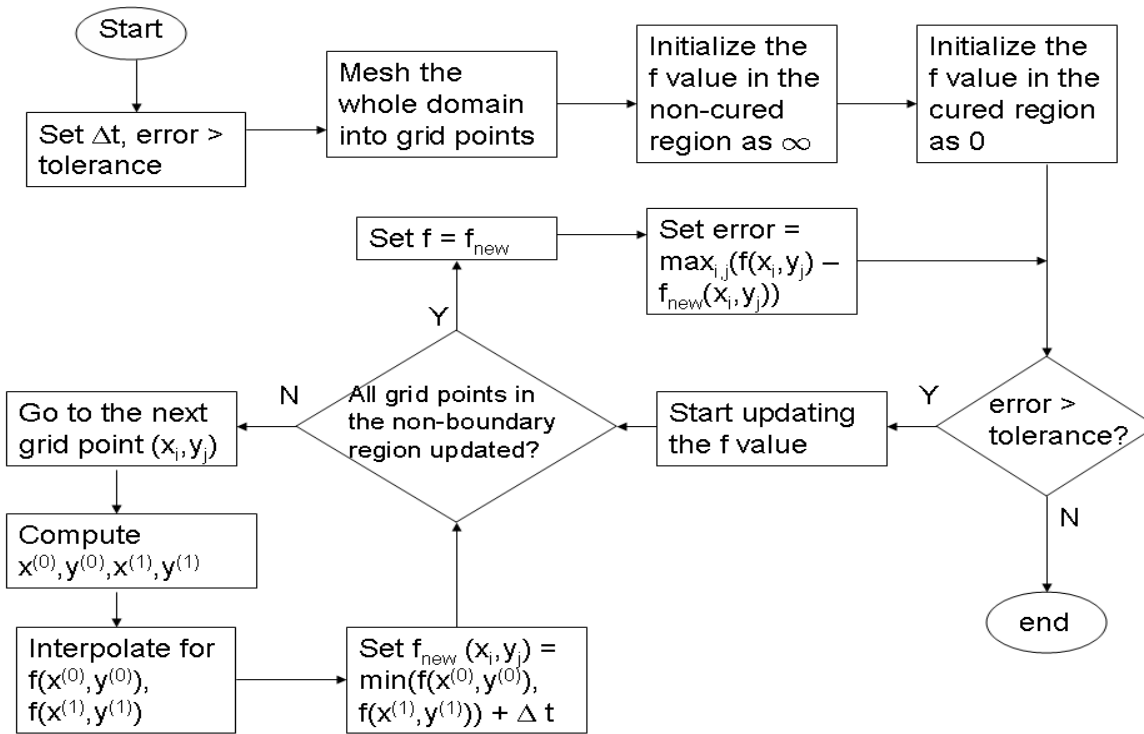

Figure 1. Flowchart for Algorithm 1

---

**Algorithm 1** Algorithm for Optimal Treatment Time.

---

```

set  $\Delta t$ , tolerance and  $error > tolerance$ ;
for  $i = 0$  to  $k_{x_d}$  or  $j = k_{y_c} + 1$  to  $N$  do
     $f(x_i, y_j) = \infty$ ;
end for
for  $i = k_{x_d} + 1$  to  $M$  and  $j = 0$  to  $k_{y_c}$  do
     $f(x_i, y_j) = 0$ ;
end for
while  $error > tolerance$  do
    for  $i = k_{x_d} + 1$  to  $M$  and  $j = k_{y_c} + 1$  to  $k_{y_d} - 1$  do
         $x^{(0)} \leftarrow x_i + \Delta^{(0)}x_i$ ;  $y^{(0)} \leftarrow y_j + \Delta^{(0)}y_j$ ;  $x^{(1)} \leftarrow x_i + \Delta^{(1)}x_i$ ;  $y^{(1)} \leftarrow y_j + \Delta^{(1)}y_j$ ;
        Interpolate  $f(x^{(0)}, y^{(0)})$  and  $f(x^{(1)}, y^{(1)})$  from the  $f$ -values on nearby grid points;
         $f_{new}(x_i, y_j) \leftarrow \min(f(x^{(0)}, y^{(0)}), f(x^{(1)}, y^{(1)})) + \Delta t$ ;
    end for
     $error \leftarrow \max_{i,j} f(x_i, y_j) - f_{new}(x_i, y_j)$ ;
     $f \leftarrow f_{new}$  for  $i = 0, \dots, M, j = 0, \dots, N$ ;
end while

```

---

cure a patient, our proposed approach was able to identify significantly shorter treatment schedules than those achieved by the local search algorithm.

Moreover, regarding the computational cost, for any

pair of  $(x, y)$ , the local search algorithm needs to be implemented over multiple starting points to identify the optimal treatment schedule. Our proposed approach, on the other hand, only needs to implement Algorithm



**Algorithm 2** Algorithm for Optimal Scheduling for state  $(x, y)$ 

---

```

Interpolate  $f(x, y)$  from the  $f$ -values on nearby grid points;
if  $f(x, y) = \infty$  then
  report the result as cannot be cured;
else
  initialize  $S$ ;
   $period \leftarrow 0$ ;
  while  $f(x, y) \neq 0$  do
     $period \leftarrow period + 1$ ;
     $x^{(0)} \leftarrow x + \Delta^{(0)}x$ ;  $y^{(0)} \leftarrow y + \Delta^{(0)}y$ ;  $x^{(1)} \leftarrow x + \Delta^{(1)}x$ ;  $y^{(1)} \leftarrow y + \Delta^{(1)}y$ ;
    Interpolate  $f(x^{(0)}, y^{(0)})$  and  $f(x^{(1)}, y^{(1)})$  from the  $f$ -values on nearby grid points;
    if  $f(x^{(0)}, y^{(0)}) > f(x^{(1)}, y^{(1)})$  then
       $(x, y) \leftarrow (x^{(1)}, y^{(1)})$ ;
       $S(period) \leftarrow 1$ ;
    else
       $(x, y) \leftarrow (x^{(0)}, y^{(0)})$ ;
       $S(period) \leftarrow 0$ ;
    end if
  end while
end if

```

---

Table 1

Parameter	Description	Example 1	Example 2
$\Delta t$	smallest chemotherapy interval	1	1
$t_c$	tumor cell life cycle	28	28
$t_h$	host cell life cycle	8	8
$r_c$	tumor cell growth constant	2	2
$\alpha_c$	tumor cell deduction percentage in chemotherapy	0.998	0.95
$\alpha_h$	host cell deduction percentage in chemotherapy	0.3	0.55
$x_d$	host cell density level for death	0.8	0.4
$y_c$	tumor cell density level for cured	0.2	0.2
$y_d$	tumor cell density level for death	4	4

*Parameters used for numerical experiment*

1 once to achieve the optimal treatment time over the whole region, which greatly reduces computational cost. Notice that, for any given  $(x, y)$ , Algorithm 2 can identify the optimal treatment schedule with negligible computation time.

## 6. Conclusions and Discussions on Model Enhancement

Optimization methods have recently been employed to identify optimal chemotherapy scheduling, which is a problem of great importance and thus needs to be adequately addressed. We developed an iterative approach for optimizing chemotherapy scheduling, which can incorporate any growth model for host and cancer

cells and is computationally tractable. Theoretical studies, simulation results as well as comparative studies demonstrate the proposed approach to be promising.

In previous sections, to illustrate the main idea, we simplified the chemotherapy model by neglecting some details such as the dose amount of chemotherapy, probabilistic moving from state to state, individualization of the parameters for different patients, and cell-cycle phase-specific scheduling. In this section, we show how our model can be enhanced to incorporate these points.

### 6.1. Choice of Dose Amount

So far, while scheduling chemotherapy, we have only considered two choices, treatment or no treatment.

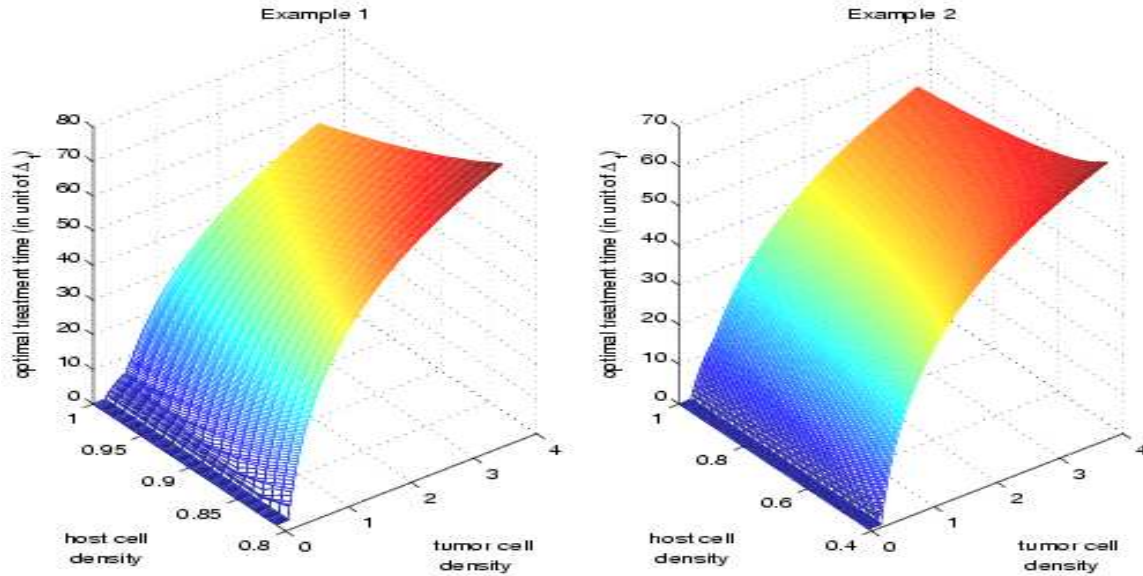

Figure 2. Graphical Results on Optimal Treatment Time

Table 2

Example	$(x, y)$	OTT	Optimal Chemotherapy Schedule
1	(0.9, 0.5)	$13\Delta_t$	1110001001001
	(0.9, 1.0)	$30\Delta_t$	111001001000100100010010010001
	(0.9, 3.0)	$57\Delta_t$	111001001000100100010010010001000100100010010010001001
	(0.95, 0.5)	$6\Delta_t$	111101
	(0.95, 1.0)	$23\Delta_t$	11110100010010001001001
	(0.95, 3.0)	$51\Delta_t$	111101000100100010010010001001000100100100010010001001
2	(0.65, 1.5)	$38\Delta_t$	1111111101101101101101101101101101101101101101101
	(0.65, 2.5)	$48\Delta_t$	11111111011011011011011011011011011011011011011011011011011011011
	(0.65, 3.5)	$56\Delta_t$	11111111011
	(0.85, 1.5)	$35\Delta_t$	11111111111101101101101101100111011
	(0.85, 2.5)	$47\Delta_t$	111111111111011011011011011011011011011011011011011011011011011011011
	(0.85, 3.5)	$54\Delta_t$	111111111111011011011011011011011011011011011011011011011011011011011

*Results on Optimal Treatment Schedule*

However, for the choice of treatment, the dose amount can sometimes vary. Although theoretically, the dose amount can be a real number, in practice it can only be a multiple of a smallest unit. For this reason, we can assume the dose amount  $l = 0, 1, 2, \dots, n$  in the suitably chosen unit, where  $n$  is the largest allowable dose amount to be used for a patient. Then instead of a 0-1 choice at each  $(x, y)$ , we are facing  $n + 1$  choices of  $l$ , with  $l = 0$  standing for no treatment. Use  $\Delta^{(l)}x, \Delta^{(l)}y$  to denote the cell density increment in the corresponding case, and follow the same reasoning in section 2, we

can reach a similar recurrent equation to the one in (1),

$$f(x, y) = \min_{l=1, \dots, n} f(x + \Delta^{(l)}x, y + \Delta^{(l)}y) + \Delta t,$$

for the corresponding region of  $x$  and  $y$ . The theorem on the existence and uniqueness of the regular solution still hold with the same proof. The algorithm just needs to be changed slightly according to the new equation.

**6.2. Probabilistic Moving among the States**

By assuming cell density moves from  $(x, y)$  to  $(x + \Delta^{(l)}x, y + \Delta^{(l)}y)$  during  $\Delta t$  with dose amount  $l$ , we are

Table 3

Example	$(x, y)$	Algorithm 1 & 2	Local Heuristic Search Algorithm
1	(0.9, 0.5)	$13\Delta_t$	$13\Delta_t$
	(0.9, 1.0)	$30\Delta_t$	$30\Delta_t$
	(0.9, 3.0)	$57\Delta_t$	$68\Delta_t$
	(0.95, 0.5)	$6\Delta_t$	$6\Delta_t$
	(0.95, 1.0)	$23\Delta_t$	$24\Delta_t$
	(0.95, 3.0)	$51\Delta_t$	$58\Delta_t$
2	(0.65, 1.5)	$38\Delta_t$	$38\Delta_t$
	(0.65, 2.5)	$48\Delta_t$	$49\Delta_t$
	(0.65, 3.5)	$56\Delta_t$	$59\Delta_t$
	(0.85, 1.5)	$35\Delta_t$	$35\Delta_t$
	(0.85, 2.5)	$47\Delta_t$	$47\Delta_t$
	(0.85, 3.5)	$54\Delta_t$	$55\Delta_t$

*The Optimal Treatment Time Achieved through the Proposed Approach and the Local Search Algorithm in [13]*

essentially assuming this were a deterministic movement from one state to another. However, in reality, there are many other factors affecting the changing of cell density, which means there is much randomness in  $\Delta^{(l)}x$  and  $\Delta^{(l)}y$ .

Due to this randomness, we change our definition of  $f(x, y)$  to be the optimal "expected" time to cure, and reconstruct our recurrent equation, taking probability into account. In general, suppose at state  $(x, y)$ , after a period  $\Delta t$  with treatment level  $l$ , the state will move to  $(x', y')$  with probability density function  $p^{(l)}(x', y')$ , then we can derive our new equation as

$$f(x, y) = \min_{l=1, \dots, n} \int_{\mathcal{D}} f(x', y') p^{(l)}(x', y') dx' dy' + \Delta t,$$

where  $\mathcal{D}$  is a suitable region for the integral. We can therefore modify our algorithm according to the given  $p^{(l)}(x', y')$ . If the solution space is discretised, we may employ Blackwell's theorems for stochastic dynamic programming to prove the existence and uniqueness of the solution.

### 6.3. Cell-cycle Phase-Specific Scheduling

As discussed in [13], the effect of the drug used in chemotherapy on the cell growth also depends on the phase during the cell-cycle. Both host and tumor cells are assumed to be sensitive to the chemotherapeutic agents in only a few of the cell-cycle phases, which are defined as critical phases. Due to this reason, cell-cycle dependent chemotherapy is shown to favor periodic treatment.

We can incorporate this point into our model by increasing the dimension of the state space from 2 (host

and tumor) to 4 (host and tumor, in critical and non-critical phases). More specifically, at a certain time, we have a 4-dimensional vector  $(x_a, x_b, y_a, y_b)$  to denote the cell densities for both the host and tumor cells in critical and non-critical phases. Then assume after time period  $\Delta t$ , it moves to state  $(x'_a, x'_b, y'_a, y'_b)$ . We can get parallel results as we did in previous sections.

### 6.4. Individualization

Typically, the parameters in the density increment functions such as  $\Delta^{(0)}x$  should vary from person to person. At the very beginning of the chemotherapy, we can only use the average parameters at hand. During the chemotherapy treatment, we can test the cell density level for the patient from time to time, and then adjust the parameters. Statistical methods can be employed to achieve this. Each time when the parameters are changed, we need to resolve our equations for better scheduling.

### Acknowledgments

We thank the two anonymous referees for their insightful comments and suggestions, which have led to an improved paper.

### References

- [1] Wu, X., Zhu, Y. (2001) A global optimization method for three-dimensional conformal radiotherapy treatment planning. *Phys. Med. Biol.* **46**, 107-119.

- [2] Malinen, M., Huttunen, T., Kaipio, J.P. (2003) Thermal dose optimization method for ultrasound surgery. *Phys. Med. Biol.* **48**, 745-762.
- [3] Cox, E.B., Woodbury, M.A., Myers, L.E. (1980) A new model for tumor growth analysis based on a postulated inhibitory substance. *Comput. Biomedical Res.* **13**, 437-445.
- [4] Swan, G.W. (1987) Optimal control analysis of a cancer chemotherapy problem. *J. Math. Appl. Medicine Biol.* **4** 171-184.
- [5] Murray, J.M. (1990) Optimal control for a cancer chemotherapy problem with general growth and loss functions. *Math. Biosci.* **98** 273-287.
- [6] Pereira, F.L., Pedreira, C.E., De Sousa, J.B. (1994) A new optimization based approach to experimental combination chemotherapy. *Frontiers Med. Biol. Engrg.* **6** 257-268.
- [7] Athanassios, I., Barbolosi, D. (2000) Optimizing drug regimens in cancer chemotherapy by an efficacy-toxicity mathematical model. *Comput. Biomedical Res.* **33** 211-226.
- [8] Agur, Z. (1986) The effect of drug schedule on responsiveness to chemotherapy. *Ann. Acad. New York Sci.* **504** 274-277.
- [9] Agur, Z., Arnon, R., Schechter, B. (1988) Reduction of cytotoxicity to normal tissues by new regimens of phase-specific drugs. *Math. Biosci.* **92** 1-15.
- [10] Cojocaru, L., Agur, Z. (1992) Theoretical analysis of interval drug dosing for cell-cycle-phase-specific drugs. *math. Biosci.* **73** 1-31.
- [11] Agur, Z., Dvir, Y. (1994) Use of knowledge on  $\{\phi_n\}$  series for predicting optimal chemotherapy treatment. *Random and Comput. Dynam.* **2** 279-286.
- [12] Ubezio, P., Tagliabue, G., Schechter, B., Agur, Z. (1994) Increasing 1-b-D-arabinofuranosylcytosine efficacy by scheduled dosing intervals based on direct measurement of bone marrow cell kinetics. *Cancer Res.* **54** 6446-6451.
- [13] Agur, Z., Hassin, R., Levy, S. (2006) Optimizing Chemotherapy Scheduling Using Local Search Heuristics. *Operations Research* **5** 829-846.
- [14] Dibrov, B., Zhabotinsky, A., Neyfakh, Y., Orlova, M., Churikova, L. (1985) Mathematical model of cancer chemotherapy. Periodic schedules of phase-specific cytotoxic-agent administration increasing to selectivity of therapy. *math. Biosci.* **73** 1-31.
- [15] Webb, G.F. (1990) Resonance phenomena in cell population chemotherapy models. *Rocky Mountain J. Math.* **20** 1195-1216.
- [16] Johnson, M., Webb, G.F. (1996) Resonances in age structured cell population models of periodic chemotherapy. *Internat. J. Appl. Sci. Comput.* **3** 57-67.
- [17] Swan, G.W. (1990) Role of optimal control theory in cancer chemotherapy. *math. Biosci.* **101** 237-284.
- [18] Swierniak, A. (1995) Cell cycle as an object of control. *J. Biol. Systems.* **3** 41-54.
- [19] Swierniak, A. (1996) Optimal control problems arising in cell-cycle-specific cancer chemotherapy. *Cell Prolif.* **29** 117-139.

---

Received 24 January 2007; revised 25 June 2007; accepted 2 November 2007