

## New Detection Method for Alkylphenol Traces in Water Based on an Integrated Electrochemical Cell Sensor

## Nouvelle méthode de détection de traces d'alkylphénols dans l'eau basée sur un capteur à cellule électrochimique intégrée

Ayman Chmayssem and Didier Hauchard

Volume 28, Number 1, 2015

URI: <https://id.erudit.org/iderudit/1030005ar>

DOI: <https://doi.org/10.7202/1030005ar>

[See table of contents](#)

### Publisher(s)

Université du Québec - INRS-Eau, Terre et Environnement (INRS-ETE)

### ISSN

1718-8598 (digital)

[Explore this journal](#)

### Cite this article

Chmayssem, A. & Hauchard, D. (2015). New Detection Method for Alkylphenol Traces in Water Based on an Integrated Electrochemical Cell Sensor. *Revue des sciences de l'eau / Journal of Water Science*, 28(1), 35–40.  
<https://doi.org/10.7202/1030005ar>

### Article abstract

In order to evaluate the efficiency and to monitor the treatment of organic micropollution by advanced oxidation processes, we have developed a new detection method based on the use of an electrochemical sensor for alkylphenol detection in water. This sensor, integrating a three-electrode cell configuration, is a commercial screen-printed electrode (SPE-110GPH) that can be used for alkylphenol detection continuously by mean of a derived flow cell. The working electrode is modified by a graphene layer that enhances the sensor sensibility. The experimental conditions were optimized for the sensor incorporated into the flow cell. Linearity ranges, repeatability and accuracy were studied as well as the detection limits for each alkylphenol. The lowest detection limit was obtained with bisphenol A (60 nM) and the measurement ranges achievable with the SPE-110GPH electrode allow the continuous monitoring of treatment processes.

# NEW DETECTION METHOD FOR ALKYLPHENOL TRACES IN WATER BASED ON AN INTEGRATED ELECTROCHEMICAL CELL SENSOR

*Nouvelle méthode de détection de traces d'alkylphénols dans l'eau basée sur un capteur à cellule électrochimique intégrée*

---

AYMAN CHMAYSSSEM<sup>1,2</sup>, DIDIER HAUCHARD<sup>\*1,2</sup>

<sup>1</sup>Institut Sciences Chimiques de Rennes, UMR CNRS 6226, Équipe CIP, École Nationale Supérieure de Chimie Rennes, 11, allée Beaulieu, CS 50837, 35708 Rennes Cedex 7

<sup>2</sup>Université Européenne de Bretagne, 5, Boulevard Laënnec, 35000 Rennes, France

Reçu le 15 novembre 2014, accepté le 27 janvier 2015

---

## ABSTRACT

In order to evaluate the efficiency and to monitor the treatment of organic micropollution by advanced oxidation processes, we have developed a new detection method based on the use of an electrochemical sensor for alkylphenol detection in water. This sensor, integrating a three-electrode cell configuration, is a commercial screen-printed electrode (SPE-110GPH) that can be used for alkylphenol detection continuously by mean of a derived flow cell. The working electrode is modified by a graphene layer that enhances the sensor sensibility. The experimental conditions were optimized for the sensor incorporated into the flow cell. Linearity ranges, repeatability and accuracy were studied as well as the detection limits for each alkylphenol. The lowest detection limit was obtained with bisphenol A (60 nM) and the measurement ranges achievable with the SPE-110GPH electrode allow the continuous monitoring of treatment processes.

**Key words:** *Water treatment, Alkylphenol detection, Electrochemical sensor, Screen-printed electrode.*

## RÉSUMÉ

Dans le cadre de l'évaluation de l'efficacité et du suivi du traitement de la micropollution organique, par procédés d'oxydation avancée, nous avons développé une nouvelle méthode de détection qui repose sur l'utilisation d'un capteur électrochimique pour la détection des alkylphénols dans les eaux. Ce capteur, qui intègre une configuration de cellule électrochimique à trois électrodes, est une électrode sérigraphiée commerciale (SPE-110GPH) utilisée pour détecter les alkylphénols en continu dans une cellule de mesure à circulation. Le fonctionnement du capteur incorporé dans cette cellule à circulation a ainsi été optimisé. Les domaines de linéarité, la répétabilité des analyses et la justesse des réponses ont été étudiés ainsi que la limite de détection. La limite de détection la plus basse a été obtenue avec le bisphénol A (60 nM) et les plages de mesure accessibles avec l'électrode SPE-110GPH permettent d'envisager le contrôle en continu des procédés de traitement.

**Mots-clés:** *Traitement de l'eau, Détection d'alkylphénols, Capteur électrochimique, Screen-printed electrode.*

## 1. INTRODUCTION

Many recent articles in the literature have reported alkylphenols as endocrine disrupting compounds (ROGERS *et al.*, 2013; KOTULA-BALAK *et al.*, 2011). They are used in large quantities and particularly discharged in wastewater (COLIN, 2009). Bisphenol A (BPA) is used as a monomer in the production of polycarbonate and epoxy resins and as an antioxidant or stabilizing agent for plastics (RYKOWSKA and WASIAK, 2006); 4-nonylphenol (4-NP), 4-octylphenol (4-OP) and 4-*tert*-octylphenol (4-*tert*-OP) are the main alkylphenols that are widely used in domestic detergents, pesticide formulations and industrial products as non ionic surfactants. Several analytical techniques are available for alkylphenol detection. Such methods include high performance liquid chromatography (LUNDANES *et al.*, 1998) and gas chromatography-mass spectrometry (Ministère du Développement durable, de l'Environnement et des Parcs de Québec, 2012). However, many of these methods require complicated pretreatment procedures and are very expensive and time consuming. Other methods based on electrochemical sensors have been reported in the literature (ZHENG *et al.*, 2012; ZHOU *et al.*, 2013). However, these sensors are unable to perform measurements continuously. In this paper, we report the development of a new detection method for alkylphenols in water, based on an integrated electrochemical cell sensor. This method is essentially characterized by its simple operation, low-cost, relatively short response time and its high efficiency. All these advantages make it an ideal tool for quantitative measurement of alkylphenols in water and/or industrial effluents and in particular allow the continuous monitoring and control of treatment processes.

## 2. MATERIAL AND METHODS

### 2.1 Apparatus and electrodes

Voltamperometric measurements have been carried out with a Potentiostat/Galvanostat Autolab (PGSTAT 101) purchased from Metrohm. Integrated software (Nova 1.13) was used for analysis control and data processing. The electrochemical polypropylene (FLWCL-P) circulation cell and the screen-printed-electrodes (SPE-110GPH) were commercially obtained from DropSens (Figure 1). The screen-printed electrode integrates on the same ceramic support the carbon working electrode modified by a graphene layer, the silver reference electrode and the carbon auxiliary electrode. A HPLC pump (Waters) was used to deliver a stable solution flow that can be handled by the circulation cell. A homemade support was used to maintain a mini-cell serving as a tank for the electrochemical solution in circulation (Figure 2).

### 2.2 Reagents and solutions

Bisphenol A (BPA), 4-nonylphenol (4-NP), 4-octylphenol (4-OP) and 4-*tert*-octylphenol (4-*tert*-OP) were purchased from Sigma-Aldrich (high purity grade). Working alkylphenol solutions were prepared in demineralized water. Phosphate-buffered solution was used as the supporting electrolyte. Demineralized water was obtained in our laboratory by an appropriate production system (Millipore). Other solvents and chemicals used were of analytical reagent grade. All the prepared solutions were stored in the dark at 4°C when they were not in use. All the measurements were carried out at lab temperature.

## 3. RESULTS AND DISCUSSION

### 3.1 Electrochemical behavior of alkylphenols

The electrochemical behavior of the alkylphenols at the SPE-110GPH electrode was investigated by cyclic voltammetry. At a scan rate of 0.05 V/s, an anodic peak localized at 0.3 V was observed on the voltammogram (Figure 3) for 4-nonylphenol. However, this peak can move slightly to higher potential toward 0.4 V, depending on the alkylphenol and its concentration in solution, as well as the flow rate. In all cases, no reduction peak was observed in the reverse scan. This shows that oxidation of alkylphenols at the graphene modified screen-printed electrode is a totally irreversible process. On the other hand, the effect of changing the scan rate potential was studied from 0.01 V/s to 0.35 V/s in order to determine the behavior of the alkylphenols on the graphene modified screen-printed electrode. A slope of 1 was observed for all alkylphenols ( $\log I_p$  versus  $\log v$ ) indicating that the alkylphenol oxidation process on the sensor surface is kinetically limited by adsorption and not by diffusion.

### 3.2 Effect of electrode modification

In order to study the effect of modification of the graphene layer at the working electrode sensor, a comparison between the response of the unmodified working carbon electrode and the graphene modified working carbon electrode was made in the same solution and under the same experimental conditions (Figure 3). Results show that the graphene modification layer improves the capacitive current and also the intensity of the oxidation peak current of the alkylphenol. The use of the graphene-modified electrode enhances by a factor of 6× the oxidation peak current, compared to the unmodified carbon working electrode, which results an enhancement of the electrode sensitivity. For this reason, we chose the graphene-modified screen-printed electrodes for alkylphenol detection.

## Graphene modified Screen-Printed Electrodes

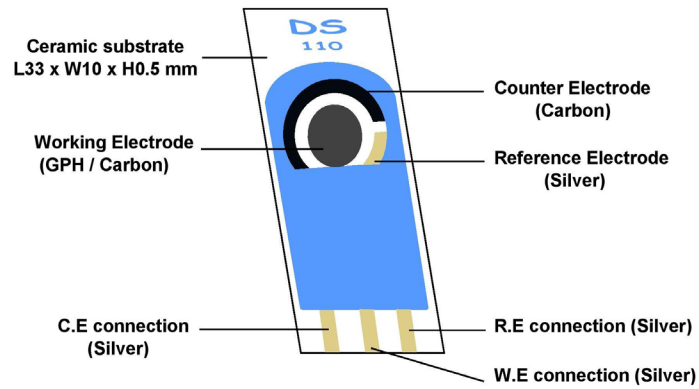

Figure 1. Schematic representation of the graphene-modified screen-printed electrode  
*Représentation schématique de l'électrode sérigraphiée (SPE-110GPH)*

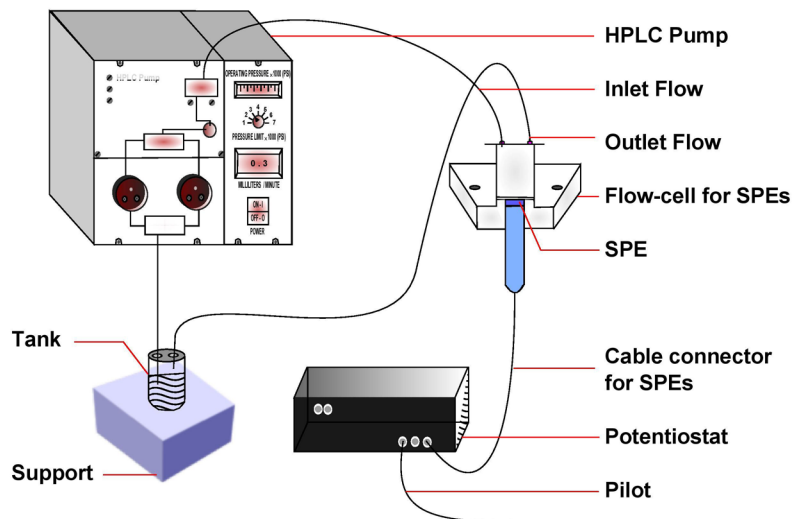
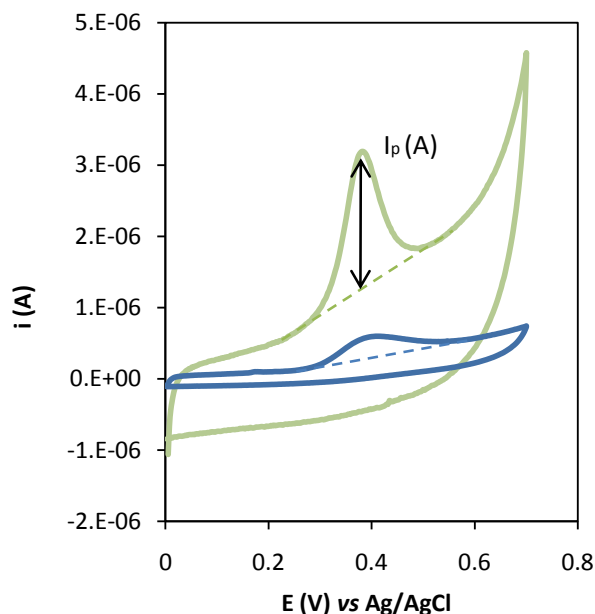

Figure 2. Schematic representation of the experimental setup used during the manipulation of the SPEs in a hydrodynamic environment.

*Schéma du montage expérimental utilisé lors de la manipulation avec les SPE en mode hydrodynamique.*



**Figure 3.** Cyclic voltammograms in phosphate buffer (0.1 M, pH 7) at  $v = 0.05$  V/s obtained with unmodified SPE (blue curve) and graphene-modified screen-printed electrode (green curve) in the presence of 4-nonylphenol (7.33  $\mu$ M)  
*Allures des voltammogrammes cycliques obtenus avec SPE-110 non modifiée (courbe bleu) et celle obtenue avec SPE-110GPH modifiée avec le graphène (courbe vert) dans un tampon phosphate (0.1 M, pH 7) à  $v = 0.05$  V/s en présence d'une concentration de 7.33  $\mu$ M en 4-nonylphénol*

### 3.3 Optimization of alkylphenol detection at SPE-110GPH

In order to improve the sensitivity of the proposed sensor, some experimental parameters were investigated and optimized. It was found that alkylphenol oxidation on the graphene-modified electrode requires reactivation of the working electrode surface before every new measurement. This reactivation is needed to eliminate the oxidation products formed on the working electrode surface. The second step involves accumulation of the alkylphenols in circulation on the electrode surface, since the oxidation process is limited by adsorption. The behavior of this sensor in a circulation cell was optimized to maintain the dual steps consecutively. An optimized time of four minutes was fixed between two consecutive measurements to obtain repeatable current peak intensity.

### 3.4 Detection limit

A series of alkylphenol samples with different concentrations was analyzed in the presence of phosphate buffer as the supporting electrolyte by the graphene-modified screen-printed electrode, to investigate the analytical capabilities of the sensor. The determination of the detection limit was made separately for each alkylphenol. Bisphenol A

had the lowest detection limit among the alkylphenols (60 nM). For the other alkylphenols, the calculated detection limit was 0.1  $\mu$ M for 4-nonylphenol (4-NP), 0.5  $\mu$ M for 4-octylphenol (4-OP) and 0.1  $\mu$ M for 4-tert-octylphenol (4-tert-OP).

### 3.5 Linearity range

The cyclic voltammograms obtained with the SPE electrodes as a function of the solution concentration of the alkylphenols are presented in figure 4. The calibration curves were obtained from the oxidation peak current measurements. They showed a linear response for bisphenol A, 4-octylphenol and 4-tert-octylphenol (Table 1) over a sufficiently wide concentration range (2 decades) to envisage the use of this sensor to control process efficiency. However, 4-nonylphenol showed a polynomial response with a good correlation coefficient.

### 3.6 Repeatability and accuracy

Repeatability of the SPE response was investigated and tested in the same laboratory, by the same analyst, the same equipment (HPLC pump, flow cell and potentiostat) and with the same electrode but at different times. It was calculated as the relative standard deviation from ten replicates ( $n = 10$ ). The

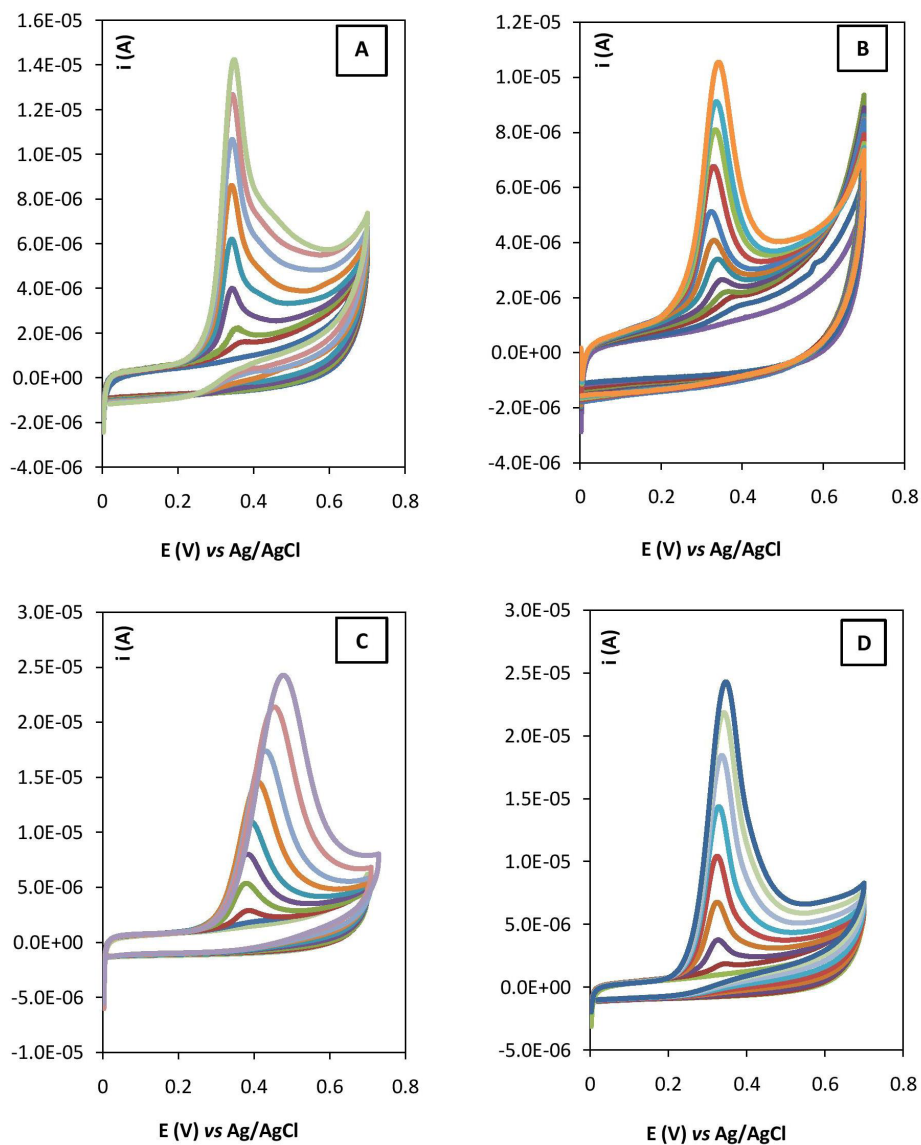

Figure 4. Cyclic voltammograms in phosphate buffer (0.1 M, pH 7) at  $v = 0.05$  V/s in the presence of increasing amounts of bisphenol A (A), 4-nonylphenol (B), 4-octylphenol (C) and 4-tert-octylphenol (D).

*Voltamogrammes cycliques dans un tampon phosphate (0.1 M, pH 7) à  $v = 0.05$  V/s en présence des quantités croissantes en bisphénol A (A), en 4-nonylphénol (B), en 4-octylphénol (C) et en 4-tert-octylphénol (D).*

**Table 1. Calibration curves for oxidation peak currents of the alkylphenols.**  
**Tableau 1. Courbes de calibration pour les courants des pics d'oxydation des alkylphénols**

Alkylphenol	Concentration range (mol·L <sup>-1</sup> )	Calibration curve equation	R <sup>2</sup>
BPA	9·10 <sup>-8</sup> – 3·10 <sup>-5</sup>	$i_p = 4,03 \cdot 10^{-7} \times C + 5,51 \cdot 10^{-7}$	0,996
4-OP	1·10 <sup>-6</sup> – 3,5·10 <sup>-5</sup>	$i_p = 6,05 \cdot 10^{-7} \times C - 1,85 \cdot 10^{-6}$	0,991
4-tert-OP	2·10 <sup>-7</sup> – 3,5·10 <sup>-5</sup>	$i_p = 7,77 \cdot 10^{-7} \times C - 1,59 \cdot 10^{-6}$	0,996
4-NP	1·10 <sup>-7</sup> – 2·10 <sup>-5</sup>	$i_p = 1,90 \cdot 10^{-8} \times C^2 + 6,88 \cdot 10^{-8} \times C + 1,22 \cdot 10^{-7\#}$	0,997

\*  $i_p$  represents the peak current in amperes and  $C$  is the concentration in mol·L<sup>-1</sup>

# quadratic calibration curve

repeatability of bisphenol A, 4-nonylphenol, 4-octylphenol and 4-tert-octylphenol, were respectively: 4.52%, 4.01%, 4.04% and 4.84%. In the other hand, the accuracy of the developed method was studied at a given concentration level by comparing the expected value with the average of the results obtained by extrapolation from the calibration curve of each alkylphenol for ten replicates. The calculated accuracy was between 90% and 95% for the different alkylphenols, indicating that the developed method for alkylphenol detection on the graphene-modified screen-printed electrode has a good repeatability and very high accuracy.

## CONCLUSION

In this work, a novel method was established to detect and quantify alkylphenols on a graphene-modified screen-printed electrode. The proposed sensor demonstrates a rapid, sensitive and selective detection of alkylphenols as well as good repeatability and high accuracy. The detection limit for alkylphenols was very low, especially for bisphenol A. Calibration curves cover wide concentration ranges for all studied alkylphenols, which should permit continuous detection with the sensor integrated into a circulation cell connected to an advanced oxidation process.

## REFERENCES

- COLIN, R. (2009). Les perturbateurs endocriniens dans l'eau. *L'eau, L'industrie, Les nuisances*, 319, 63-67.
- KOTULA-BALAK, M., E. POCHEC, A. HEJMEJ, M. DUDA and B. BILINSKA (2011). Octylphenol affects morphology and steroidogenesis in mouse tumor Leydig cells. *Toxicol. In Vitro*, 25, 1018-1026.
- LUNDANES, E., T. GREIBROKK and A.M. KVISTAD (1998). Determination of alkylphenols in water samples by solid-phase extraction on to poly(styrene-divinylbenzene) and quantification by liquid chromatography with UV-detection. *Chromatographia*, 48, 707-713.
- MINISTÈRE DU DÉVELOPPEMENT DURABLE, DE L'ENVIRONNEMENT ET DES PARCS DE QUÉBEC. CENTRE D'EXPERTISE EN ANALYSE ENVIRONNEMENTALE DU QUÉBEC (2012). Détermination des alkylphénols dans les eaux usées: extraction liquide-solide, dérivation et dosage par chromatographie en phase gazeuse couplée à un spectromètre de masse, MA. 404 – Alkylphénols 1.0, 14 p.
- ROGERS, J.A., L. METZ and V.W. YONG (2013). Review: Endocrine disrupting chemicals and immune responses: a focus on bisphenol-A and its potential mechanisms. *Mol. Immunol.*, 53, 421-430.
- RYKOWSKA, I. and W. WASIAK (2006). Properties, threats, and methods of analysis of Bisphenol A and its derivatives. *Acta Chromatogr.*, 16, 1-21.
- ZHENG, Q., P. YANG, H. XU, J. LIU AND L. JIN (2012). A simple and sensitive method for the determination of 4-n-octylphenol based on multi-walled carbon nanotubes modified glassy carbon electrode. *J. Environ. Sci.*, 24, 1717-1722.
- ZHOU, W.-S., B. ZHAO, X.-H. HUANG and X.-D. YANG (2013). Electrochemical determination of 4-nonylphenol on graphene-chitosan modified glassy carbon electrode. *Chinese J. Anal. Chem.*, 41, 675-680.