

Culture

Representation of Self and Reincarnation Among the Dene-Tha

Jean-Guy Goulet



Volume 8, numéro 2, 1988

URI : <https://id.erudit.org/iderudit/1085909ar>

DOI : <https://doi.org/10.7202/1085909ar>

[Aller au sommaire du numéro](#)

Éditeur(s)

Canadian Anthropology Society / Société Canadienne d'Anthropologie (CASCA), formerly/anciennement Canadian Ethnology Society / Société Canadienne d'Ethnologie

ISSN

0229-009X (imprimé)

2563-710X (numérique)

[Découvrir la revue](#)

Citer cet article

Goulet, J.-G. (1988). Representation of Self and Reincarnation Among the Dene-Tha. *Culture*, 8(2), 3–18. <https://doi.org/10.7202/1085909ar>

Résumé de l'article

Chez les Dénés du nord-ouest de l'Alberta les rêves et les visions constituent des moyens par lesquels les esprits des défunts qui vivent sur « l'autre terre » sont observés. Il arrive qu'on observe l'esprit d'un défunt entrer dans le corps d'une femme afin de s'y réincarner. Cette observation détermine alors la manière dont on se représente cet enfant à naître d'une part, et la manière dont cet individu se représentera à lui-même et à autrui d'autre part. Le présent travail cherche à décrire et à analyser la représentation de soi comme individu réincarné parmi les Dénés. Le travail conduit ainsi à un compte rendu anthropologique des rêves, visions, et représentations de soi, au sein d'une population autochtone.

Tous droits réservés © Canadian Anthropology Society / Société Canadienne d'Anthropologie (CASCA), formerly/anciennement Canadian Ethnology Society / Société Canadienne d'Ethnologie, 1988

Ce document est protégé par la loi sur le droit d'auteur. L'utilisation des services d'Érudit (y compris la reproduction) est assujettie à sa politique d'utilisation que vous pouvez consulter en ligne.

<https://apropos.erudit.org/fr/usagers/politique-dutilisation/>

Érudit

Cet article est diffusé et préservé par Érudit.

Érudit est un consortium interuniversitaire sans but lucratif composé de l'Université de Montréal, l'Université Laval et l'Université du Québec à Montréal. Il a pour mission la promotion et la valorisation de la recherche.

<https://www.erudit.org/fr/>

Representation of Self and Reincarnation Among the Dene-Tha

Jean-Guy Goulet
University of Calgary

Dreams and visions are conceived by the Dene-tha of northwestern Alberta as "ways of knowing with the mind". In particular, dreams and visions are a means through which the spirits of deceased persons may be encountered and observed. In some cases the spirit of the deceased is "seen" or "known" to enter a woman's body to reincarnate as a child. This "knowledge" determines the way in which Dene-tha represent themselves to themselves and to each other. The purpose of this paper is to describe and analyze the Dene-tha representation of self as reincarnated individual. Thus, the paper draws the implications for an anthropological understanding of dreams, visions, and self among an aboriginal population.

Chez les Dénés du nord-ouest de l'Alberta les rêves et les visions constituent des moyens par lesquels les esprits des défunts qui vivent sur «l'autre terre» sont observés. Il arrive qu'on observe l'esprit d'un défunt entrer dans le corps d'une femme afin de s'y réincarner. Cette observation détermine alors la manière dont on se représente cet enfant à naître d'une part, et la manière dont cet individu se représentera à lui-même et à autrui d'autre part. Le présent travail cherche à décrire et à analyser la représentation de soi comme individu réincarné parmi les Dénés. Le travail conduit ainsi à un compte rendu anthropologique des rêves, visions, et représentations de soi, au sein d'une population autochtone.

Ethnographers usually find themselves in strange places, that is, places that are strange to them but, of course, not strange to the people who belong and live in those places. In such situations anthropologists cling "to the injunction to see things from the native's point of view" (Geertz, 1977: 481). Anthropologists, however, do not have direct access to the hearts and minds of the people whose lives they seek to understand. To determine the ways in which people think, feel and perceive, anthropologists must understand "the symbolic forms - words, images, institutions, behaviours - in terms of which, in each place, people actually represent themselves to themselves and to one another" (Geertz, 1977: 483).

In his 1938 essay, *Une catégorie de l'esprit humain: la notion de personne, celle de "moi"*, Marcel Mauss advocated that our taken-for-granted conceptions of self and person were in truth the product of a unique western social history. Drawing from the ethnographic record, he showed how other people with different social histories - the Zuni, the Kwakiutl, the Arunta, etc. - held quite distinct and contrasting notions of self and person (Mauss, 1987). The notion is widely accepted today that the ways in which self or person is conceived of are "mediated through culturally salient clusters of ideas, symbols, and emotions" (Levy, 1983: 127). Thus representation of self among

the Balinese (Geertz, 1973), the Tallensi (Fortes, 1973), the Lugbara (Middleton, 1973), the Ilongot (Rosaldo, 1980), the Dinka (Lienhart, 1987), the Chinese (Elvin, 1987) or the Inuit (Saladin d'Anglure, 1988) become the focus around which complex sets of indigenous assumptions about the world and themselves, however implicit, are discussed.

Careful determination of symbolic forms and informed interpretation of them are, therefore, the means whereby anthropologists come to understand the perspective from which natives perceive people, events and things. Symbolic forms are treated as the vehicles for concepts that determine how people look at life and how they try to live it. These concepts are "experience-near" (Geertz, 1977: 481), that is, they are naturally and effortlessly used by individuals to define what they or their fellows see, think and imagine, and which they readily understand when similarly applied by others. Indeed, in most instances people may fail to recognize that there are any concepts involved in what they do and say: "That is what experience-near means - that ideas and the realities they disclose are naturally and indissolubly bound up together" (Geertz, 1977: 482).

My intention in this paper is to search out and analyze a subset of Dene symbolic forms and experience-near concepts pertaining to birth, health, illness and death. The data is derived from various conversations over five years with twenty-one Dene from Chateh, a native community in northwestern Alberta.¹ During those years I had numerous opportunities to be with people as they commented on an illness, a death, a pregnancy or a birth. The beginning and the end of a human life, as well as periods of illness, constitute moments of transitions, points of important changes, in the lives of individuals and of collectivities. In such circumstances individuals cannot help but use the experience-near concepts provided by their culture to define what is happening both to them and around them.

The conversations, excerpts of which are offered throughout this paper, contain many references to salient topics of Dene life: vision-quest, animal helpers, dreams, travel to heaven, loss of soul, being born again.² These topics constitute the background against which the Dene attempted to explain to the ethnographer events lived by themselves or by someone very close to them. It is noteworthy that all thirty-five individuals offered examples of events lived by themselves or a very close relative. One hundred and thirty-one individuals, nearly fifteen per cent of the population of Chateh, are part of the conversations, either as speakers or as referents. The events and the Dene

understanding of them as shared with the ethnographer were indeed experience-near. When asked if they could comment on the type of event they were discussing with examples from other Dene households, all replied they could not do so as they did not really know what the other cases were. This attitude reflects the Dene definition of "knowing" as perceiving directly with one's senses or mind. In the strict Dene sense of the term, what one does not experience or perceive directly, one does not "know".³

The analysis of Dene experience-near concepts will accomplish four objectives. First, it draws the major dimensions and elements of a Dene worldview that defines the boundaries within which individuals look at life and try to live it. Second, it establishes how the Dene perceive illness as a critical moment in their lives when the soul is separated from the body, a separation that may lead to death unless the proper relationship of soul to body is restored. Third, it demonstrates how among the Dene, in the past as in the present, individuals persistently represent themselves to themselves and to one another as someone who died and who came back into the womb of a woman to be born again. Finally, it clarifies aspects of Dene thinking that investigators have so far either failed to recognize or to interpret correctly.

Dene-tha Worldview

The interviews presented and the data derived from them provide a basis for examining the experience-near concepts by which the Dene perceive themselves and their environment. These concepts can be formulated in the form of prepositions which, in my view, the Dene would recognize as truths, that is, as "facts of life" as they experience them:

- a) Human beings live either in this land, *ndahdigeh* (our land), or in *ech'udigeh* (the other land), also referred to as *yake* (heaven) and *Ndahxota digeh* (God's land);
- b) Communication, through dreams and visions, between the human beings living in "our land" and the deceased living in the "other land" is possible and normal;
- c) Animals found in the bush are representative of spiritual animal forms of life;
- d) Individuals who experience these spiritual

- animal forms in dreams or visions are known as **Dene wonlin edadihi** (people who know an animal);
- e) Knowledge of an animal helper brings power that can be used to influence, positively or adversely, one's own health and good fortune, or that of fellow-Dene;
 - f) In their sleep, Elders, known as **ndatin** (dreamers), are able to leave their bodies, to follow a trail beyond the canopy of heaven and to meet with the deceased;
 - g) Health and sickness reflect the quality of the relationship between soul and body; the greater the amount of time the soul spends away from the body, the greater the likelihood of disease, illness and death;
 - h) In an individual, the close relationship of soul and body may be disrupted by the influence either of the souls of the deceased, or by the animal helpers of fellow-Dene;
 - i) A child is clean, without sin, and immediately knows his or her way to the "other land" when he or she dies;
 - j) Following an adult's death, children are particularly threatened as the soul of the deceased may seek to take a child's soul with it on its journey to the "other land";
 - k) A person's soul may be inclined on its own to follow the soul of a deceased person, in which case that person may suffer sickness and even death;
 - l) Individuals are also susceptible to accidents, loss of health and possibly life, when their souls are lured away by the animal helpers of their enemies;
 - m) Under the circumstances described in (j), (k) and (l) dreamers and other persons with power can call upon their animal helpers either to bring the soul back to the body and restore health before death occurs, or failing that, to bring the soul back to a woman to be born again;
 - n) Rather than journey to the "other land", the soul of an individual who dies may seek on its own to enter the womb of a woman and be

born again in "this land";

- o) Individuals who are born again show in their new existence bodily and psychological characteristics that were theirs in their previous existence.

Accounts of Near-death Experiences

The Dene often claim that they are prone to illness when a close relative dies. The susceptibility is due to the soul's desire to leave the earth and accompany the soul of their kinsman or spouse to the "other land". Transcriptions of conversations with Dene illustrate how, in their view, the separation of soul and body is restored. At times, Elders and their animal helpers are seen to play a crucial role in restoring health. In the following account a Dene woman tells how her younger sister, Lisa, nearly died on the day of their father's funeral:

I do not know what I have. My eyes always hurt at this time of the year. I went to see the doctor last year but he couldn't do nothing.

Did something important happen to you around this time of the year a few years back?

Yeah, about three years ago my father died.

Did you cry when he died?

Yes, I was the first one to cry. It really hurt me when he died. It was even more difficult for my younger sister. When my dad died she almost died too. The old people from here and some old people from Meander helped her. We had to go in one room; that was the night before the funeral. My sister would not eat, and we felt her going away. When old people help they do not like light. They have to be in the dark. We were all in one room, we close the door. I sit next to my sister, and the old people sing. They call their helpers, their animal helpers, to go after my sister's soul. I guess my sister subconsciously wanted to stay here, but she had already started to go to my dad. That is why they had to help her. She didn't know what was going on. She was already going. When she woke up after, she asked us what we did to her. She said she had been travelling up to a fence on the other side of which was dad, and she had almost crossed that fence. That is how my sister is still here. They helped her. (14.2.83)

According to this account, Lisa's soul started to go to her father soon after he died. The separation of

the soul resulted in diminished vitality, and Lisa lost all appetite. Her family felt her going away and, therefore, called upon old people to help. The Elders sang and called upon their animal helpers to go after Lisa's soul. The animal helpers were successful in bringing Lisa's soul back to her body. Lisa was unconscious when the Elders performed their ritual activities. When she regained consciousness, she remembered having travelled to and almost crossed a fence beyond which her father stood. We are left to understand that had she crossed that fence, the Elders' animal helpers could not have gotten Lisa's soul back to her and restored her health.

The key players in this drama are the old people and their animal helpers that went after Lisa's soul.⁴ To understand who these agents are one must examine a number of closely related concepts - vision quest, power, animal helper - that are the very heart of what it means to become a Dene or a person. The conversation reported above continues with comments both on the process whereby an individual acquires an animal helper and the Dene reticence to speak about such matters:

What about these animal helpers? How does one get them?

I don't really know. Like my older brother, he never talks to us about it, but my mom told us once that one day Frederick went in the bush with little provisions, and was supposed to come back the same day, but stayed two days and two nights. On his way he had met wolves who had come to meet him; and he had been with them all that time. I guess they became his helpers. But that is all I know. We do not talk about these things. And maybe he's the only one of my brothers who is really like that. (14.2.83)

It is noteworthy that Frederick was spending the day in the bush with few provisions. In Dene thinking people with little strength and few means of sustenance are more likely than others to attract the attention of helpful spiritual beings. In effect we are told that it was the wolves that came to meet Frederick to become his helpers. From then on Frederick became known to his fellow-Dene as someone with *echint'e* (power) or as *Dene wonlin edadih* (someone who knows an animal). Like his fellow-Dene with power, he keeps in his home, near his sleeping place, a pouch or bundle containing a piece of skin, bone or other part of the kind of animal representative of his animal helper.⁵ He is prohibited from killing or eating animals representative of his animal helper. To forego this prohibition would jeopardize his life (Ridington, 1978a: 114-115; Goulet, 1982: 8-9).

Until very recently, before the onset of adolescence, almost everyone in Chateh experienced encounters with animals that became that person's power or "helper". Today, many parents still encourage their young children to spend time wandering in the bush in the hope that they will come back with an animal helper. People "describe a vision as something 'appearing in front of someone', *men-dayeh wodekeh*" (Moore, and Wheelock, 1987: 74). As a vision often comes hand in hand, with a song, "a young person who is sent to seek a vision is often told, *shin kaneyah* (go for a song)" (Moore and Wheelock, 1987: 74).

The person who knows an animal helper usually receives a gift or power to heal specific illnesses and to affect the behaviour of spiritual beings, namely the souls of living and deceased individuals, as well as the animal helpers of fellow-Dene. When the soul of an individual leaves the body on its own, as in Lisa's case, fellow-Dene with the power to assist in bringing that person's soul back to the body are called upon to help to restore health. The old people from Chateh and Meander who helped Lisa obviously enjoyed such animal helpers. Similarly when an individual becomes ill as a result of his or her soul being lured away by a deceased person's soul, fellow-Dene with the appropriate power are called to send that soul away and restore soul and health to the individual who is ill. People then say of the one that chased the deceased person's soul away: *mbechint'e t'ah i ts'une xule onla*, (with his power he made the ghost go away).

The Dene are keenly aware that individuals may abuse others through their animal helpers. One Dene put it in these words:

Dene wonlin edadih (a person knows something). His power he has it. He doesn't like what you do to him. He could think of you one night and your spirit would follow his power. He could take your spirit and you could get into an accident. (27.4.83/verbatim)⁶

Indeed, I learned that almost all accidents and instances of misfortune are interpreted by reference to such interference by a fellow-Dene's power or animal helper. In Chateh, as among many other Athapaskan groups, interpersonal and interfamilial conflicts are still handled, in part, through recourse to animal helpers (Ridington, 1968; Mills, 1986b; Smith, 1988; Sharp, 1988). If one suffers from misfortunes or accidents it is thought that they happened because one did not have the full protection of one's own animal helper, it having been temporarily distracted or overpowered by the animal helpers of fellow-Dene bearing evil intentions.

Lisa's soul was temporarily distracted or overpowered, as it were, by the soul of her deceased father. Elders and their animal helpers re-established for her the proper relationship of soul and body. Her health was restored. The following account is from Edna, whose soul also wishes to leave "this land" to join her husband in heaven:

Sometimes when I go to bed I think the way he was telling me. "If I die, I'll go right through to heaven, I'll be looking at you, don't worry." Since he died, three times I dreamed about him. I want to go to him, "No", he says, "it is not time". Maybe that is why I never get sick. (10.2.84/verbatim)

In contrast to Lisa's experience in which her father did nothing to send her back, Edna's husband refuses outright to have her come to him. She is reminded that "it is not time". As a result, her soul does not persist in its desire to join the husband in heaven and returns to her body. Edna therefore continues to enjoy good health in "this land". Close relatives or the spouse of an individual travelling to the "other land" often play a key role in sending the individual back to this earth. In some accounts this role is played by angels, Jesus or Mary.

Monica, a grandmother and a woman who "knows an animal" told me of two occasions on which she nearly died and found herself in the "other land". The first near-death experience closely followed the death of a son. She strongly desired to see her son, and her soul responded by journeying to the "other land". There, Monica reported that she met Mary, the mother of Jesus, who told her to go back as it was not time for her to die. Her account, and other evidence to come, shows that the Dene have assimilated many words, objects, and practices introduced by missionaries. It appears, however, that the Dene have absorbed these elements while interpreting them in terms of their own definitions of the world and life.⁷

Continuing her account of near-death experiences Monica told how she has recently spent more time with her son in the "other land":

Last month, all month, I was sick, but I kept it to myself. I did not tell anyone. I had dreamt that I was to be sick. I was to the other land and there I was with my son and then he told me to look down here. There was a woman lying down on a bed. He told me, "Do you know that woman?" I looked and told him, "I don't know who she is". He told me, "It is you." (15.2.83)

When Monica told me this she was recovering from an illness that had her bedridden for over a

month. The long illness had taken its toll and her emaciated face showed that she had lost much weight. Monica's appearance had changed greatly and it came as no surprise that when her son showed her a woman lying on a bed she did not recognize herself.

A few weeks later I was told by Monica's niece that the illness was due to her eating food that was prohibited to her on the basis of her having an animal helper. As Monica mentioned earlier, she is the keeper of a bundle, and all keepers of such bundles must abide by strict behavioural and dietary rules, under penalty of illness or death. While visiting away from home, unknown to her, Monica had been given food that was forbidden to her. Monica was sick enough to find herself momentarily in the company of her son in the other land. The fact that she came back to this land means either that her son sent her back to this land or that she brought herself back with the aid of her animal helper.

The Identification of Others Who are Born Again

The belief in reincarnation is widely reported by students of contemporary Athapaskan groups.⁸ Slobodin writes that "one of the most striking facts about Kutchin reincarnation is the vigorous survival of the concept" (1970:76). "Despite official Christian opposition", continues Slobodin, "all Kutchin I have known, and most northern Metis in addition, accept the reality of the kind of occasional reincarnation described in this paper" (1970:76). Occasional reincarnation is also reported to occur among the Hare: "A man is reincarnated as a man and a woman as a woman, but some persons are not reincarnated at all" (Hultkrantz, 1973: 114). A somewhat different situation exists among the Beaver. According to Mills (1986b: 89) the Beaver believe that all souls, even those that get to heaven, "will eventually reincarnate back on earth."

Among Slobodin's informants who considered reincarnation a fact of life were three ordained Anglican ministers and a dozen devout Roman Catholics. Similarly, Mills observed among the Beaver that "women who consider themselves good born-again Christians have no compunctions against describing the reincarnation-based traits of their children and grandchildren to each other" (1986b: 90). In Chateh, people who claim to be Catholics also perceive many of their fellow-Dene as the reincarnation of other fellow-Dene. The deep belief in reincarnation reported by Petitot among the

Dene over a century ago is still very much alive among contemporary Athapaskan populations (Goulet, 1982).⁹

The people in Chateh believe as do the Kutchin and Hare that some, but not all, souls of deceased individuals come back to be born again. Most often a dreamer foresees the reincarnation, and may foretell it. Very often souls of deceased individuals seeking to be born again are sighted around the burial ground, or are seen at night around people's homes. The deceased person seeking reincarnation is usually seen in the dreams of either of the parents to whom he or she will be born. Very often, the infant bears some physical mark which was characteristic of the deceased individual. As the child grows, he or she exhibits preferences, memories, and personality traits that were characteristic of that person in his or her previous existence.

Occasionally someone is born again, not out of his or her desire, but because of a decision made by the parents or relatives. Thus, in the following account, a woman goes to the Elders and asks them to redirect the soul of her deceased daughter, Julie, to her womb so it may be born again:

Would you believe the daughter we lost came back to us through some Indian superstition, through three persons we paid. We went to superstition people, his (my husband's) dad, Brock and Delwin and they helped us with their power. They had her done to us again. We did not want a boy to come, she was done again as a girl. (27.4.83/verbatim)

"Superstition people" were paid, following which they used their power or animal helpers to assist the parents in their petition. Payment to individuals with power is in the form of gifts. These gifts are usually tobacco and objects such as shirts, moccasins, a piece of moosehide, gloves, knives, etc. The gifts are said to be for the animal helpers of the individual who calls on them to cure or assist the one who brings the gifts.

In their discussion of individuals dying and being born again, Dene speakers very rarely use the expression reincarnation. They use, as in the case of this woman, phrases such as he or she was done to us again. This English phraseology is very close to the Dene terms denoting such a person: **Dene andats'indla**, (a person who was made again by others).

This woman, as other English-speaking Dene nowadays, refers to aboriginal beliefs and practices as superstitions and to dreamers

and people with power as superstition people. This usage should not be construed as evidence that bilingual Dene have effectively internalized Webster's definition of the term as "a belief or practice resulting from ignorance, fear of the unknown, trust in magic or chance, or a false conception of causation." When I asked for the translation of superstition to the Dene language I was invariably given the phrase **Dene wonlin edadih**. When I asked for the translation of this Dene expression to English, I was never given the word "superstition". Rather, I was always given the English phrases "someone who knows an animal helper" or "someone with power". Interestingly enough, the translation of English to Dene and back to English leads to a body of aboriginal experiences and knowledge that is widely shared by young and old alike and taken for granted by them as they live their lives, and present themselves to themselves and to each other.

The following is the account of a man, Austin, who over two years dreamed of his deceased nephew. This nephew, Austin says, was then born to him as a daughter (see Figure 1):

That Vivian (C-1), she is Jacob's brother (C-2). Over two years, he kept coming to my place. I dream always about him. A year later, my child was born. Then Vivian came. She had a dark spot along here, like that guy (shows where on body). When we were kids we lived at Zama. Jay (B-4) had a dog really mean. One day Dwight (C-2) was feeding that dog. From up onto a wagon box, he fell down and got bitten by the dog. He had a scar here (points to body part). After baptism they call her Vivian. I call her Belinda. Dwight's dad knows that and he calls her **te** (my son), and she understands. (27.5.82/verbatim)

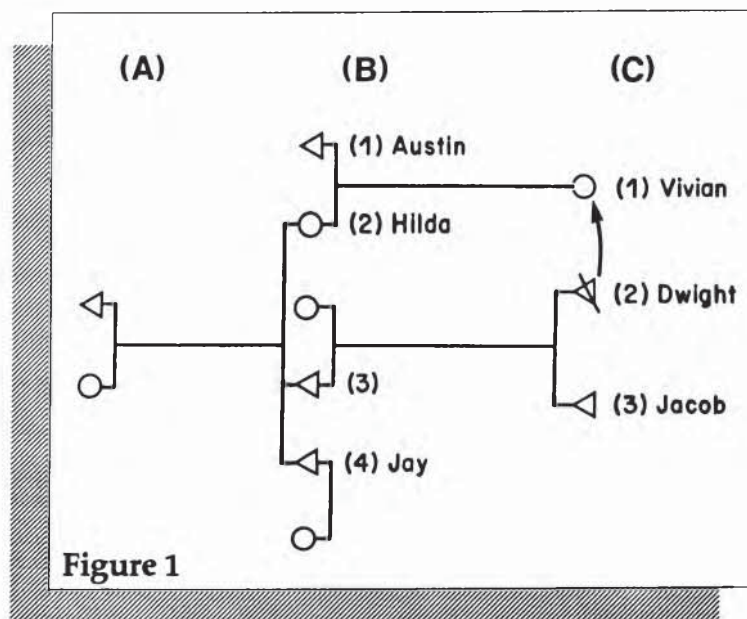

Figure 1

The dreams about Dwight are the first indication that his soul has not gone to heaven, but lingers around "this land" to be born again. Confirmation that it is Dwight who has reincarnated is found in the fact that Vivian is born with a physical mark exactly where Dwight had been bitten by a dog. Austin raises his daughter with the knowledge of who she really is. Similarly, Dwight's father calls Vivian "my son", even though she is a girl and was born to his brother-in-law. In Austin's view, "If a person dies, and he still wants to keep on living, but he dies, it comes back to stay on the world. That one that dies, that child takes his place, he becomes that one that died. It's only one person." This view is widely shared by the Dene, young and old.

In the course of my fieldwork I was unexpectedly drawn into the dynamics of a family which was expecting a child to come back to life. In February 1983 I paid a visit to Lois (A-2), the grandmother of Christabel, who had died a tragic and violent death many months earlier. (See Figure 2 below.) Lois told me that her brother Arthur (A-1), a dreamer, had told her that his daughter Roberta (B-1) was now pregnant with Christabel (C-2). Lois went on to instruct me to pay a visit to Roberta (B-1): "Go tell her she should refrain from drinking, traveling and getting beaten up, for the baby she is carrying is not her baby, but our baby". Lois continually, then and later, referred to Roberta's child (C-1), as *sebaby* (my

baby) or *ndahbaby* (our baby).

I carried out Lois's instructions and continued visiting the family. A few months went by without my being aware of any developments in the family's expectation that their deceased child was to be born again. Roberta had already given birth to her child when Christabel's maternal aunt, Marcella (B-4), related what her daughter had to say in the following way:

My girl called me the other night and told me our little girl had come to her. She had dreamed of her. In her dream, I was standing by the coffin but the coffin was empty. She saw Christabel running home across the field. She was all o.k. except for her front teeth, they were a little rusty. Christabel told her that mom (Lois) should not worry about her, that she is coming back this time as a boy, that she always wanted to be a boy. That is true, she always had her slingshot, and didn't want to play with her dolls. They called her tomboy. They say she came back as this little boy of Roberta. And I would not have believed it if it wasn't for this tuft of black hair coming out just here, long black hair, just here (she points to a location where injury had been inflicted) and all the rest is just baby hair. (26.6.83/verbatim)

Marcella and her relatives had no difficulty with the notion that Christabel, whom they thought to be reincarnated as Roberta's son, still appeared in the dreams of fellow-Dene. Christabel is here referred to as "our little girl". In the dream Christabel is seen running across a field. Christabel then tells the dreamer that their grandmother, Lois (A-2), should not worry about her, for she is coming back, this time as a boy. Marcella then explains that she was convinced that Christabel had come back when she saw a tuft of black hair growing on the head of Roberta's son, exactly where Christabel had suffered a mortal injury.

The following day, June 27, 1983, I went to Marcella and told her I would like to see the baby. Marcella immediately told her daughter we were going to see the baby. We walked to Roberta's house. Roberta, her husband and the children were all there. Marcella picked up the small baby from his bed and said, "Let's go to a cool place". She then

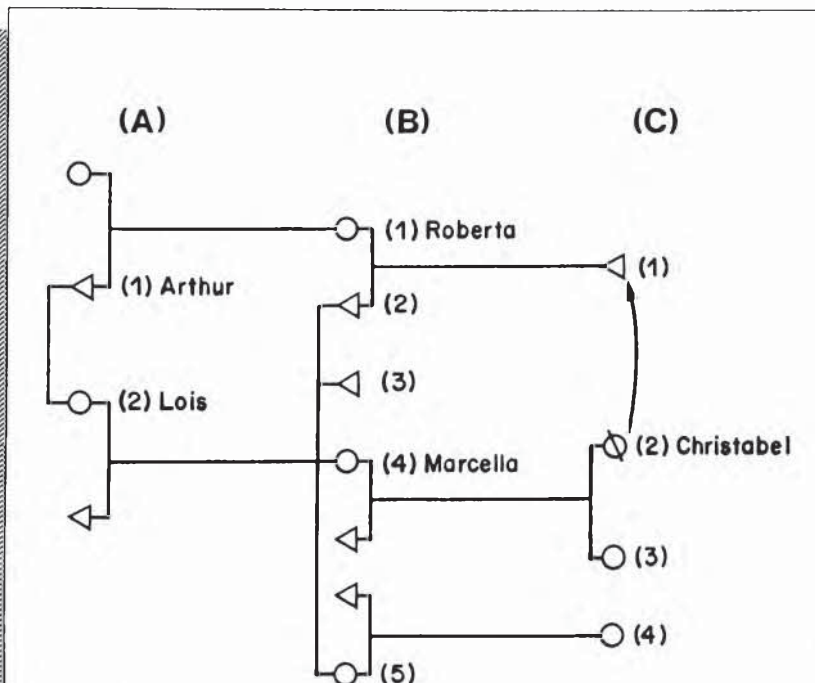

Figure 2

stepped outside the house and sat directly in the sun on the porch. A cool breeze nevertheless refreshed us. She kissed the baby, held it near her and then showed me the tuft of black hair behind his ear and temple. The tuft of black hair was very conspicuous. At least an inch long, it stood out on a head otherwise covered with thinly spaced baby hair, much shorter and of a much lighter colour. Marcella then told me, "Now you believe", apparently convinced this evidence would induce in me, as it had induced in her, the conviction that Christabel had indeed been reincarnated as predicted by the dream of her uncle and confirmed by the dream of her daughter.¹⁰

In an earlier publication I argued that among the Dene, dreams and visions are reliable ways of knowing with the mind (Goulet, 1987). I then described my own experience of a vision of a deceased Dene, an experience that I and the Dene see as typical of the visions they also experience at times.¹¹ To this day, however, I cannot take for granted, as do the Dene, that the figures "seen" in dreams or visions had their origin in a deceased person who was manifesting herself to people who are left behind. I tend to think of the visions as part of the subjective experiences that constitute a larger grieving process following the tragic death of a young person with whom we had all been close. The Dene would agree with this view, but would include the deceased person as an active participant in the grieving process.

In such cases I could not and cannot spontaneously use the experience-near concepts the Dene naturally and effortlessly use to define what they and their fellows see, think, and imagine. This is not to say that I can or want to simply dismiss or ignore the subjective experiences and external evidence the Dene see as the basis for their beliefs. In the last section of this paper, "Thinking about experience-near concepts", I will further discuss my position on Dene experiences and beliefs.

Identifying Oneself as Someone Who is Born Again

"It is possible to sum up the dialectic formation of identity", writes Peter Berger, "by saying the individual becomes that which he is addressed as by others" (1969:16). Significant others, responsible for the socialization of a given individual, mediate to him or her a sense of subjective identity. In all societies and cultures children are "socialized to be a

designated person and to inhabit a designated world" (Berger 1969: 16). What happens then among the Dene, when someone is continually referred to and addressed as someone who was alive, died and came back to live again in "this land"?

The following account illustrates some aspects of socialization that led a Dene, constantly addressed as the woman he reincarnated, to think of himself and behave in ways that were consistent with this identity mediated to him by significant others (see Figure 3, below):

I [Jacob, (C-1)], was a little girl (C-3) growing up at the residence, and then one day I got sick. I went to the hospital and died over there. And one year later I came back with Amelia (B-2) holding my arm. I came back to the hospital in Edmonton where my mother Hilda (B-1) is, and I came back to life as Jacob. (23.3.84/verbatim)

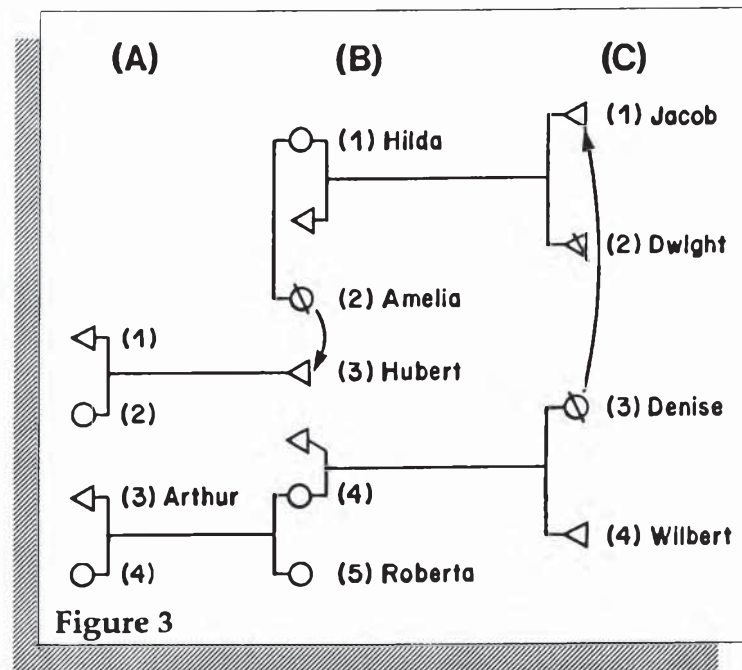

Figure 3

Jacob refers to himself first as a girl, Denise, who was brought up in the school residence in Chateh. Overtaken by sickness Denise was sent to a hospital in Edmonton, where she died. A year later, Hilda, a woman from Chateh, is hospitalized in Edmonton. Hilda then sees her deceased sister, Amelia, appear to her with Denise so Denise can be born again:

She [my mother] was in the hospital and while she went to the hospital her sister Amelia died. And she [Amelia] came in and said: "I am walking to you with Arthur's granddaughter" (C-3). She [my mother] said Amelia told her: "I arrive here next

to you for her to be born again". Then she [Amelia] went out. "I fell unconscious", mom said. Arthur's granddaughter grabbed her from behind. "I fell unconscious", she said. From there Amelia went to the neighbours and was made again. She is Hubert (B-3). My mother calls him "my sister" because of that.

Jacob's mother first sees and hears her deceased sister Amelia. After being told that Arthur's granddaughter is to be given back to her to be born again, Jacob's mother falls unconscious. I asked Jacob what this meant. He said that his mother was awake when she had the vision of her two deceased relatives. Jacob added that his mother's experience differed from that of Arthur (A-3) who, through a dream of his own, was also shown that his granddaughter was coming back. It may be remembered, from a previous case illustration, that Arthur is Christabel's grandfather and one of the community's dreamers. Jacob also informed us that after she secured the reincarnation of Denise, Amelia herself went to the neighbours to be born again, this time as a boy, now known as Hubert (B-3).

As was the case with Christabel's coming back to life, so it was the case of Jacob that a number of individuals were informed through dreams or visions that a close relative was being born again. According to the Dene it makes little difference whether one experiences the visit of a deceased person's soul while awake in a vision, or while asleep in a dream. In many accounts it is actually difficult to determine whether people are telling of events that took place while they were asleep, or while they were awake and experiencing a vision. Both dreams and visions constitute reliable sources of information regarding events unfolding in the spiritual realm.

Jacob continues his account of being born again with the typical reference to a birthmark that established that he was indeed "she" come back to life:

You want to see the birthmark. (He raises his shirt and a pale line, one inch long can be seen.) It is the birthmark of Arthur's granddaughter. I am a man who came back. That is why when I was young I looked like a girl. Wilbert's mother (B-4), she knows that I am his sister.

As in most other accounts of reincarnation reported to me in Chateh, a birthmark stands out as physical evidence that the same person has come back to live again. To tell who Jacob is one has to know what every Dene in the community knows, he is she, Denise reincarnated. "They knew I came back

as Denise", Jacob added. "They always told me who I was."

In Chateh, there is more to gender identity than meets the eye. Although Jacob is a man, Wilbert's mother (B-4) "knows" him as her son's sister. Similarly, Jacob's mother "knows" that Hubert is her sister, Amelia, come back to life; Jacob's mother addresses Hubert accordingly. In an earlier account we also learned that Dwight's dad "knew" that his son was born again as the daughter of Austin, his brother-in-law, and addressed her as "my son". In these cases, as in the others that came to my attention over the years, the kinship relationships existing in a previous existence are maintained with one who is perceived as being born again. Among close relatives at least, the use of kinship terms of address reflect the identity and the genealogical relationships of the individual in his previous existence. In cases of cross-sex reincarnation, a woman in this life is addressed as my son, my brother, and conversely, a man is addressed as my daughter, or my sister.

As Jacob relates, not only did his relatives and neighbours address him in terms of who he was in the past, they also at times asked him to take on the appearance of his real self:

I will be a baby girl they thought. But I was. Now they knew I had come back, and they loved me very much. If I put my hair behind, from a distance I am as a woman, and when they tell me I am a girl, I colour my eyes and my mouth, and sometimes they ask me to put my hair behind like this, and they tell me, "Yes, you look like a woman". (14,3,84/verbatim)

Due to physiological and biological changes, Jacob grew out of his role of a girl. One day he told me with pride, "Finally, I look like a man, I have a moustache, my face is kind of pale." As do other Dene who see themselves and are seen by others as being a person of the opposite sex who has been born again, Jacob will most probably soon marry and take on the responsibilities of a family. Even then, he will be addressed by his close relatives in terms of his former existence, as daughter or sister.

In all the cases examined so far, figures appearing in visions or in dreams, birthmarks, personality traits, kinship terms of address, and behavioral characteristics, stand as symbols to be interpreted. These symbols are the vehicles for experience-near concepts of self-identity and of identification of others. In many cases, these symbols accumulate to build an image of he as she or she as he, and to express a general knowledge of people's underlying gender identity.

Thinking about Experience-near Concepts

In March 1972, Hultkrantz interviewed Harold Cook, a twenty-two-year-old Hare Indian visiting in Stockholm. This interview demonstrated to Hultkrantz "the tenacity with which some youths today cling to the past heritage, and particularly that part of it which contains the life values-religion" (1973: 114). Of interest to Hultkrantz was the belief held by Harold Cook and his family that he reincarnated his mother's father. Indeed, Harold is known among the Hare by the name of his forefather, Little Fox.

When Harold imparted "that each year his grandmother walks to her husband's grave on his death day and sings to him" (Hultkrantz, 1973: 140), the information was discounted and dismissed on the grounds that the grandmother's attitude was "incompatible with the belief in reincarnation" (Hultkrantz, 1973: 148, note 47). The author appears to assume that if the woman really believed that her husband had reincarnated she would not engage in the activities reported by her grandson. This assumption, I will show, is most probably wrong.

In Chateh, when I heard Dene report the kind of behaviour attributed to Harold's grandmother, I too was tempted to write this information off as contradicting the belief in reincarnation. In my mind, people who claimed they were raising a reincarnated relative could not also hold that this relative was in heaven and could be prayed to. Yet, time after time, I came across Dene who strongly held to both propositions.

The following excerpts of a long conversation with a husband and wife illustrate this point of view. The couple is the one who went to superstition people to have their deceased daughter, Julie, born again to them. At the time of this conversation, their son, Antonio, had difficulties with the law and his parents were praying to his deceased sister, Julie, to help him in his dealings with the justice. Surprised at this information, I asked what they meant. The husband then related the following:

My daughter has become an angel. I pray to my father, I pray to my daughter and to my sister-in-law. "My daughter help me, remember your brother, my baby you have become an angel. Your mother is my wife. Look at your sister, at your brother." I pray to her with my mind. I think about them, and if something happens she helps me. When I go to sleep I also pray to my child, my sister-in-law, my father. I don't tell my wife. It's with my mind I pray. (27.4.83/verbatim)

In answer to my query the man first reports that his daughter has become an angel. Other Dene confirmed that deceased individuals, especially children and Elders, turn into angels in heaven, **yake ewot'ine andaja**. The man states that he also prays to his sister-in-law and father, and specifies that he does so with his mind.

As none of this information helped clarify the contradiction I had in mind, I asked another question, which the man, and then the woman attempted to answer:

How is it you pray to her and you say she is in your house, reincarnated? How can this be?

Every individual has a soul, **mbets'une ndahtsi andahtse'dla**. (They make her soul come back to us.)

My little girl, she had a birthmark on her leg and also here (She touches her right wrist). Now this little baby had the same marks. On her leg her marks are still to be seen, That is why she is my daughter, I know.

The husband reminded me first, that everyone has a soul, and second, that they, superstition people, made their daughter's soul come back to them. The woman then strongly reiterated their conviction that their daughter was indeed reincarnated. She supported this statement with the evidence of marks found on their daughter at the time of her previous existence as well as at the time she "was done again".

Again, the statements made by the parents did not address the issue I attempted to raise. I therefore pressed my point further and insisted that I could not understand how it was they could pray to their daughter and yet say she was with them in their home. To my surprise, the man grabbed the lid of a jar laying on the table, put it next to me and said, "Take it!" As I proceeded to pick it up, he quickly took the lid with his heavy, strong hand and said: "See you can't take it, you would have to fight me." He then removed his hand from the lid, and again, told me to take it, which, this time, he let me do. He then added the following:

See you can take it. I tell you everything. We teach you, we say everything to you. If there is a guy who doesn't know anything, if you don't say the right words, and we don't like it, you are in trouble. We don't like it. Like you write what we tell you, we could walk away, we go away, what do you do? Nothing, you can't write any more.

I suddenly understood that I had been rather rude and insensitive in my insistence in asking them to consider a contradiction that I, and obviously not they, had in mind. I was suddenly reminded that I was the "guy" who did not know anything. In truth, they were the teachers and I the learner. I realized their patience was running short. Were I to persist in saying the wrong words, I may well end in trouble, alienate them, and find myself with nothing to write. As I lifted the lid from the table, I said I understood what he meant. We then proceeded quietly again, me to take notes and they to discuss other issues related to animal helpers and power.

The conversation reported above left me confused. I still did not understand how or why people would hold to such apparently contradictory propositions. I decided to take the matter up with Dene friends with whom I was in the habit of consulting when I experienced difficulties in my dealings with other Dene. I summarized for them what the parents had told me. Our conversation proceeded then as follows:

I don't understand how they can pray to their daughter in heaven and think she is with them in their house, reincarnated. Do you understand?

Yeah, it is possible, it can happen. They die, the parents know they become angels but the parents, somehow or another, they know when he is reincarnated. There is always a sign to know it is their child that is reincarnated.

They became angels?

Yea, everybody knows that a kid who is clean and has no sins becomes an angel when he dies. (19.4.83/verbatim)

I reminded the woman that the parents insisted that their children were born again. She answered "They know, there are signs". I then said one would have to conclude their children are in two places, to which she simply affirmed "That's the way it is".

This woman's response to my puzzlement is similar to the one I received from the man and woman with whom I first attempted to discuss how one can say a child is an angel in heaven and reincarnated in this land. This woman, as other Dene I talked to, does not hold the view that following a person's death one soul goes to the "other land" while another soul remains in "this land" to be born again. The Dene simply know that a deceased person may be in two places, in the "other land" and in "this land" as someone reincarnated. I still could not simply accept this way of thinking, and pursued

with more questioning:

You don't have any problem with that? Do you understand how I can make a problem out of that?

No.

Let's take this cup for example. If you tell me it is here on the table and that it is also in the kitchen, then I could say to you, it is either on the table or in the kitchen but it cannot be in two places at the same time.

But talking about something we can see it can create problems. But it is things you can't see but you believe in, it's faith.

At this point in our conversation it came to me as a surprise that my Dene friend could not understand how I was having a problem with Dene statements. When I provided an example to illustrate what I saw as a problem with Dene statements, the woman immediately commented that problems would obviously arise if we talked of visible things. The problem does not arise with things such as the souls of the deceased, for then it becomes a matter of faith.

I asked her what would happen if I told Dene *andatse'dla uh mbeyune edu yak'e k'eh aat'in* (the person is made again and her soul is not in heaven)? Her response was emphatic:

If you say that the parents will think you laugh at them or don't believe them.

Why?

They might think you are mocking their faith, it is going to upset them. I would think the parents believe that you believe in the same thing. If you say that, they think you laugh at them.

I immediately reassured her that this was certainly not my intention, but that I still had difficulty accepting what I was being told. She understood that indeed it took a lot of faith to believe as the Dene did, but insisted there were signs that make people believe. She then added: "If someone like you has doubts about it, there are signs to show you, signs that people can show you, to make you believe."

I asked her what kind of signs people could show me. She answered: "Like, the people that had died, had scars, or habits of doing something, make people recognize who they were before". Her response brought to mind my experience with Christabel's aunt, Marcella, who, showing me the tuft of black hair on the baby's head, had said emphatically, "See, now you believe!"

I had been startled at Marcella's assertion. She obviously thought, as other Dene do, that seeing the evidence would make me believe. While the Dene bring to the act of looking at a birthmark the assumption that it is a sign, I do not. To transform something into a sign calls into action an experience-near concept, one the Dene effortlessly and naturally use to define what they see. Here, I think, is the root of the differences in perception and belief I felt so keenly between the Dene and myself.¹²

To see instances of birth, health, illness and death as the Dene view them is in a sense an impossible task for the ethnographer. What the fieldworker may accomplish, however, is determining carefully and interpreting sensitively the symbolic forms - institutions, behaviours, images, words - that are the vehicles for the experience-near concepts in terms of which the Dene look at life and try to live.

Although the literature contains numerous references to the vigorous survival of the concept of reincarnation among Athapaskan groups, none pertained to the Dene-tha of northwestern Alberta. To my knowledge the literature makes no mention of the concept of the soul being simultaneously in heaven and reincarnated among Athapaskan groups. Hultkrantz, it was shown, came close to recognizing this conceptualization among the Hare, but mistakenly dismissed the revealing data on the grounds that it was incompatible with the belief in reincarnation. The recognition of this conceptualization among the Dene-tha allowed for the clarification of an aboriginal thought process whereby physical evidence is transformed into a sign that a newborn child is indeed someone who died, remained in "the other land", and is born again in "this land".

It was shown that the Dene-tha conceptualization of cases of reincarnation are best understood in the context of their assumptions about the world and themselves. Among the Dene-tha, dreaming, travelling to the "other land" for relatively short periods of time, and coming back to "this land" to be made again, are all understood as journeys of the soul away from and back to the body. This general conception of the relationships between soul and body shed light on births, illnesses, and deaths. People living in "this land" and the deceased living in "the other land" communicate with each other as well as influence the good and bad fortunes of each other. The detailed case illustrations and analysis not only demonstrate the vigorous vitality of an aboriginal conception of life; they also provide a basis for comparisons with similar belief systems reported among other Athapaskan groups.

The ethnographic data and analysis of them presented here lead to other interesting questions.

How, for instance, does the information about reincarnation relate generally to Dene-tha interpretations of knowledge, power and individualism? Is a person's medicine power carried over between former and later lives? Is there a structural pattern in the kinship connection between the individuals "known" to be reincarnated and the fellow-Dene through whom they "are made again"? If a pattern can be found, how does it relate to other features of Dene-tha social organization? Additional research along with a more thorough analysis of all the data gathered over five years of fieldwork will help in addressing these questions in greater depth.

Anthropological descriptions and analysis of aboriginal belief systems may acquire special significance at a time when groups appear before the Courts and press their claims to aboriginal rights to land and self-government. For example, the Gitksan-Wet'uswet'ene tribal Council are currently before the Supreme Court of British Columbia to demonstrate that they have title to their land. "Their case is phrased so that they have to demonstrate that they have maintained their culture, religion and spiritual beliefs without giving up jurisdiction over their territory" (Mills, personal communication). In the end, aboriginal belief systems may well prove to be the grounds on which aboriginal groups successfully reconstitute their rights to self-government and life in this land, "our land".

ACKNOWLEDGEMENTS

I thank Christine Hanssens and Carol Smith for their comments on earlier drafts of this paper. I am grateful to Pat Moore for his revisions of the Dene orthography. I am also grateful to Carol Schafer for her careful editing of the manuscript and to Avis Nedza for her assistance in the preparation of the manuscript. The research time made possible through fellowships, over five consecutive years, beginning in January 1980, while I was at Saint Paul University's Canadian Research for Anthropology, is gratefully acknowledged. And most of all I thank the Dene-tha who have generously allowed me to live in Chateh, among them, and to participate in their lives.

NOTES

1. Fictive names are given to individuals to preserve their anonymity as well as that of their families. As far as possible, I have chosen names that do not occur in Chateh. In the literature the Dene-tha of this community are re-

ferred to either as Slavey (Asch, 1981: 348) or as “the Dene-tha branch of the Beaver Indians” (Smith, 1987: 444). Chateh is the name of the reservation also known as Assumption.

2. While conducting fieldwork I try to record verbatim, as much as I can of the conversations I enjoy on various Dene topics. To this end, I always carry a pen and writing pad. With most Dene under the age of forty, conversations were conducted in English, perhaps with references to Dene terms used to express the issues discussed. With Dene over the age of forty, conversations were generally in Dene. Over the years, I have gained sufficient mastery of the local dialect to record these interviews or conversations in written form. I often taped the conversations I had with Elders, transcribed them and translated them to the best of my ability, and then reviewed the results with bilingual informants. The transcripts from my field notes which appear in this paper are followed by a reference to the date on which the conversation took place and, in most cases, with an indication that the transcription is verbatim. In the absence of such an indication the notes were written down from memory within twenty-four hours of the actual conversation.

3. In conversations with Dene individuals, I noticed how they tended to construct their statements carefully so as to declare whether the information they conveyed was first- or second-hand. The following excerpt from a conversation illustrates this pattern and is related to the Dene conception of knowledge, its acquisition and transmission.

1. 2. 3. 4. 5. 6. 7.
tu kaoot'ah ghedi ghats'ediin ehdih wonh'a adehsi

1. 2. 3. 4. 5. 6. 7.
water for we go they said it is said he said because I say

Converted to English phraseology the informant's statements reads as follows: “I say they said ‘we are going for water’ because he (my son) said this is what is said.”

When asked whether they actually said, “We are going for water”, the informant answered that he did not know for he did not actually hear them say this. What the informant knew is what he heard with his own ears from his son. Asked whether his son knew if they said, “We are going for water”, the informant answered in the negative, for his son, also, was relating second-hand information.

To *know* is to perceive directly with one's senses. What one has not experienced or perceived directly, one does not know. Much of what is said and repeated in conversations is, therefore, not knowledge, in the strict Dene sense of the term. It follows that the credibility of individuals identified as links in the chain of transmission of information is crucial in evaluating the merit of whatever is said. That is why, among the Dene, one is careful to identify the source of whatever information is conveyed. I believe this is also why the Dene I talked with never discussed instances of reincarnation from other Dene households. Although Dene individuals had heard of

cases of reincarnation in other households, such cases were not considered to be “known” in the strict sense of the Dene word **edahdih** (I know).

4. The Chipewyan, Smith (In Press: 8) informs us, also refer to such animals as “animal helpers”. “It has been common for anthropologists and others to refer to such an animal as a ‘guardian spirit’. The Chipewyan simply say: ‘the animal that helps him/her’”.

5. Emile Petitot, O.M.I., who visited the Loucheux four times between 1865 and 1977 writes of similar practices: “...les Indiens se procurent, dès qu'ils ont reçu l'initiation, une peau ou quelque partie de l'animal afin d'en fabriquer une amulette, un talisman. Griffes, queues ou ailes d'oiseaux, peaux d'hermine ou de putois, oiseaux empaillés ou étalés... On portait ces objets sur soi. On en décorait les pirogues, les berceaux et les couches; et les époux prenaient leur repos sous le regard protecteur de l'animal tutélaire, suspendu au-dessus de leur lit” (Savoie, 1971: 80). Similar practices are reported by other students of Athapaskan groups: Duchaussois (1923: 218-219) for the Dogrib, Ridington (1976: 56-57 and 1978b: 9-17) for the Beaver, and Smith (1973: 8) for the Chipewyan.

6. It is on the basis of a similar statement that I earlier wrote that the phrase **Dene wonlin edadihi** means ‘a person who knows what is’ (Goulet, 1982: 6). I was then in error. I simply assumed, as is the case in this conversation, that the informant had spoken Dene and then immediately offered a translation to English. This assumption was strengthened by the knowledge that in English **Dene** and **edahdih** mean ‘person’ and ‘he/she knows’, respectively. What I failed to recognize then was that the expressions **wonlin** and **wonlin ghede** stand for ‘animal’ living in the bush. The correct translation of **Dene wonlin edadihi** is ‘a person who knows an animal’.

7. See Goulet (1982: 1-18) and Ridington (1987: 8-9) for a discussion of Athabaskan aboriginal beliefs in relation to Christianity.

8. For instance see Mills (1986a) for the Carrier or Wet'suwet'en and Beaver; Goulet (1982) for the Dene-tha; Honingmann (1981: 448) for the Kaska; MacLachlan (1981: 464) for the Tahltan; McClellan, (1981b: 487) for the Tagish, and (1981c: 501) for the Tutchone; Clark (1981: 59) for the Koyukon; Hosley (1981: 620) for the Kolchan; Savishinsky and Hara (1981: 321) for the Hare, and Smith (1981: 279) for the Chipewyan.

9. More than a century ago, E. Petitot, O.M.I., reported that, while among the Dene he tried in vain to dispel a young woman's opinion that she had lived an earlier life under another name and other appearances, and failed equally in his attempts to discredit a grandmother's conviction that she should claim the child of a neighbour as her own, a child she “knew” to be her own son reincarnated: “Je n'ai pu chasser de l'esprit d'une jeune fille la persuasion où elle était d'avoir vécu antérieurement à sa naissance sous un autre nom et avec des traits autres que ceux que je lui connaissais; ni empêcher une vieille femme de revendiquer la propriété de l'enfant de sa voisine, sous le spécieux prétexte qu'elle reconnaissait en lui l'âme émigrée de son fils décédé” (Savoie, 1970: 79).

10. From her fieldwork among the Wet'suwetene, Mills (1986b: 5) reports a most striking example of the correspondence between birth marks on the reported reincarnation and wounds or scars on the previous personality. "A girl was born with a double birth mark on her back which corresponds to the location where the presumed previous personality was stabbed by scissors." In this paper (1986b: 18), Mills informs us that Dr. Ian Stevenson "has recently completed a large work on the evidence of birth marks and birth defects as they relate to reported cases of reincarnation including color photographs of birth marks and birth defects with the corresponding wounds or scars or lesions on the reported previous personality. Once published, this work may have a profound impact on the medical and genetic profession, for which it is intended."

11. My experience of a vision of a deceased Dene was of Christabel. A full account of my involvement with this family and its expectations that their daughter was coming back to life should include the data presented her along with the experiences described in Goulet (1987: 7-8).

12. As Hanson has shown in a masterful way in his book, *Perception and Discovery* (1969), seeing is always informed by knowledge, however implicit. As Bateson (1987: 92) reminds us, the processes whereby we perceive various objects, people or events are essentially unconscious and beyond our control: "I know which way I aim my eyes and I am conscious of the **product** of perception...I know nothing of the middle process by which the images are formed."

REFERENCES

ASCH, M.

1981 *Slavey*, IN J. Helm (ed.), *Handbook of North American Indians*, Vol. 6, Washington Smithsonian Institution: 338-349.

BATESON, G. and M.C. BATESON

1987 *Angels Fear. Towards an Epistemology of the Sacred*, New York, Macmillan Publishing Company.

BERGER, P.L.

1969 *The Sacred Canopy. Elements of a Sociological Theory of Religion*, New York, A Doubleday Anchor Book.

CLARK, A.M.

1981 *Koyukon*, IN J. Helm (ed.), *Handbook of North American Indians*, Vol. 6, Washington, Smithsonian Institution: 582-601.

DUCHAUSOIS, P., O.M.I.

1923 *Mid Snow and Ice. The Apostles of the North-West*, London, Burns, Oates and Washbourne.

ELVIN, M.

1987 *Between the Earth and Heaven: Conceptions of the Self in China*, IN M. Carrithers, S. Collins and S. Lukes (eds.), *The Category of the Person*, Anthropology, philosophy, history, Cambridge, Cambridge University Press: 156-189.

FORTES, M.

1973 *On the concept of the Person among the Tallensi*, IN G. Dieterlen (ed.), *La Notion de Personne en Afrique Noire*, Colloques Internationaux du Centre National de la Recherche, No. 544, Paris, Editions du Centre National de la Recherche Scientifique: 283-320.

GEERTZ, C.

1973 *Person, Time and Conduct in Bali*, IN *Interpretation of Cultures*, New York, Basic Books: 360-411.

1977 *'From the Native's Point of View': On the Nature of Anthropological Understanding*, IN J.L. Dolgin, D.S. Kemnitzer, and D.M. Scheider, (eds.), *Symbolic Anthropology. A Reader in the Study of Symbols and Meanings*, New York, Columbia University Press: 480-492.

1986 *Making Experiences, Authoring Selves*, Epilogue. IN V.W. Turner and E.M. Bruner (eds.), *The Anthropology of Experience*. Chicago, University of Illinois Press: 373-380.

GOULET, J.-G.

1982 *Religious Dualism Among Athapaskan Catholics*, *Canadian Journal of Anthropology/Revue Canadienne d'Anthropologie*, 3(1): 1-18.

1987 *Ways of Knowing with the Mind: An Ethnography of Aboriginal Beliefs*, Paper presented at 1987 CESCE Conference, Quebec City.

HANSON, N.R.

1969 *Perception and Discovery. An Introduction to Scientific Inquiry*, San Francisco, Freeman Cooper.

HONIGMANN, J.J.

1981 *Kaska*, IN J. Helm (ed.), *Handbook of North American Indians*, Vol. 6, Washington, Smithsonian Institution: 442-450.

HOSLY, E.H.

1981 *Kolchan*, IN J. Helm (ed.), *Handbook of North American Indians*, Vol. 6, Washington, Smithsonian Institution: 546-555.

HULTKRANTZ, A.

1973 *The Hare Indians: Notes on their Traditional Culture and Religion, Past, and Present*, *Ethnos*, 38(1-4): 113-152.

LEVY, R.I.

1983 *Preface*, *Ethos* 11(3): 127.

- LIENHART, G.
1987 Self: Public, Private. Some African Representations, IN M. Carrithers, S. Collins and S. Lukes (eds.), *The category of the person, anthropology, philosophy, history*, Cambridge, Cambridge University Press: 141-155.
- MacLACHLAN, B.B.
1981 Tahlitan, IN J. Helm (ed.), *Handbook of North American Indians*, Vol. 6, Washington, Smithsonian Institution: 458-468.
- McCLELLAN, C.
1981a Inland Tlingit, IN J. Helm (ed.), *Handbook of North American Indians*, Vol. 6, Washington, Smithsonian Institution: 469-480.
1981b Tagish, IN J. Helm (ed.), *Handbook of North American Indians*, Vol. 6, Washington, Smithsonian Institution: 481-492.
1981c Tutchone, IN J. Helm (ed.), *Handbook of North American Indians*, Vol. 6, Washington, Smithsonian Institution: 493-505.
- MAUSS, M.
1987 A Category of the Human Mind: The Notion of the Person; the Notion of Self, IN M. Carrithers, S. Collins and S. Lukes (eds.), *The Category of the Person, anthropology, philosophy, history*, Cambridge, Cambridge University Press: 1-25.
- MIDDLETON, J.
1973 The Notion of the Person among the Lugbara, IN *La Notion de Personne en Afrique Noire, Colloques Internationaux du Centre National de la Recherche*, no. 544, Paris, Editions du Centre National de la Recherche Scientifique: 491-506.
- MILLS, A.
1982 The Beaver Indian Prophet Dance and Related Movements Among North American Indians, Unpublished Doctoral Dissertation, Harvard University.
1985 Preliminary Investigation of Cases of the Reincarnation Type among the Beaver and Gitksan Indians, Paper delivered at the CESCE annual meetings, Toronto, May 1985.
1986a Bridging the Gap Between Individual and Collective Experience: Wet'suwet'en Belief in Reincarnation Contrasted with Gitksan and Beaver, Paper delivered at the 4th International Conference on Hunter Gatherers, London, England, September 1986.
1986b The Meaningful Universe: Intersecting Forces in Beaver Cosmology, *Culture VI*(2): 81-92.
1988 A Comparison of Wet'suwet'en Cases of the Reincarnation Type with Gitksan and Beaver, Manuscript.
- MOORE, P. and A. WHEELOCK
1987 Wolverine: Myths and Visions. Dene Traditions from Northern Alberta, Manuscript.
- RIDINGTON, ROBIN
1968 The Medicine Fight: An Instrument of Political Process Among the Beaver Indians, *American Anthropologist*, 70: 1152-1160.
- 1976 Wechuge and Windigo: A Comparison of Cannibal Belief among Boreal Forest Athapaskans and Algonkians, *Anthropologica*, 2: 107-129.
- 1978a Swan People: A Study of the Dunne-za Prophet Dance, National Museum of Man, Mercury Series, Canadian Ethnology Service Paper No. 38, Ottawa, National Museums of Canada.
1978b Metaphor and Meaning: Healing in Dunne-za Music and Dance, *Western Canadian Journal of Anthropology*, 2: 9-17.
1987 From Hunt Chief to Prophet: Beaver Indian Dreams and Christianity, *Arctic Anthropology*, 24(1): 8-18.
1988 Knowledge, Power, and the Individual in Subarctic Hunting Societies, *American Anthropologist*, 90(1): 98-110.
- ROSALDO, M.Z.
1980 Knowledge and Passion: Ilongot Notions of Self and Social Life, Cambridge, Cambridge University Press.
- SALADIN d'ANGLURE, B.
1988 Penser le "féminin" chamanique, ou le "Tiers-Sexe" des Chamanes Inuit, *Recherches Amerindiennes au Quebec*, 18(2-3): 19-50.
- SAVISHINSKY, J.S. and H. SUE HARA
1981 Hare, IN J. Helm (ed.), *Handbook of North American Indians*, Vol. 6, Washington, Smithsonian Institution: 314-325.
- SAVOIE, D. (ed.)
1970 Les Amérindiens du Nord-Ouest Canadien au 19e siècle selon Emile Petitot, Volume II: Les Indiens Loucheux. Department of Indian Affairs and Northern Development. Mackenzie Delta Research Project 10, Ottawa, Canada.
- SHARP, HENRY S.
1986 Shared Experience and Magical Death: Chipewyan Explanations of a Prophet's Decline, *Ethnology* 25: 257-270.
1987 Giant Fish, Giant Otters, and Dinosaurs: "Apparently Irrational Beliefs" in a Chipewyan Community, *American Ethnologist* 14(2): 226-235.
1988 The Transformation of Bigfoot: Maleness, Power and Belief among the Chipeqyan, Washington, Smithsonian Institution Press.
- SLOBODIN, R.
1970 Kutchin Concepts of Reincarnation, *Western Canadian Journal of Anthropology*, 2: 67-79.
- SMITH, D.M.
1973 Inkonze: Magico-Religious Beliefs of Contact-Traditional Chipewyan Trading at Fort Resolution, N.W.T., Canada, National Museum of Man, Mercury Series, Canadian Ethnology Service Paper No. 6, Ottawa, National Museums of Canada.
1982 Moose-Deer Island House People: A History of the Native People of Fort Resolution, National Museum of Man, Mercury Series, Canadian Ethnology Service, paper No. 81, National Museums of Canada.

- 1985 Big Stone Foundations: Manifest Meaning in Chipewyan Myths, *Journal of American Culture*, 8(1):73-77.
- In Press The Chipewyan Medicine Fight in Cultural and Ecological Perspective, IN R. Winthrop (ed.), *Culture and the Anthropological Tradition, Essays in honor of Robert F. Spencer*.

SMITH, J.G.E.

- 1981 Chipewyan, IN J. Helm (ed.), *Handbook of North American Indians*, Vol. 6, Washington, Smithsonian Institution.
- 1987 The Western Woods Cree: Anthropological myth and historical reality, *American Ethnologist*, 14(3): 434-48.